



aerospace
 climate control
 electromechanical
 filtration
 fluid & gas handling
 hydraulics
 pneumatics
 process control
 sealing & shielding



Dryer Products

Refrigeration Dryers, Inline & Regenerative
 Desiccant Dryers, Drain Valves

Catalog 0722-E



ENGINEERING YOUR SUCCESS.

Warning, Offer of Sale

⚠ CAUTION:

Polycarbonate bowls, being transparent and tough, are ideal for use with Filters and Lubricators. They are suitable for use in normal industrial environments, but should not be located in areas where they could be subjected to direct sunlight, an impact blow, nor temperatures outside of the rated range. As with most plastics, some chemicals can cause damage. Polycarbonate bowls should not be exposed to chlorinated hydro-carbons, ketones, esters and certain alcohols. They should not be used in air systems where compressors are lubricated with fire-resistant fluids such as phosphate ester and di-ester types.

Metal bowls are recommended where ambient and/or media conditions are not compatible with polycarbonate bowls. Metal bowls resist the action of most such solvents, but should not be used where strong acids or bases are present or in salt laden atmospheres. Consult the factory for specific recommendations where these conditions exist.

TO CLEAN POLYCARBONATE BOWLS USE MILD SOAP AND WATER ONLY! DO NOT use cleansing agents such as acetone, benzene, carbon tetrachloride, gasoline, toluene, etc., which are damaging to this plastic.

Metal bowl guards are recommended for all applications.

⚠ WARNING

FAILURE OR IMPROPER SELECTION OR IMPROPER USE OF THE PRODUCTS AND/OR SYSTEMS DESCRIBED HEREIN OR RELATED ITEMS CAN CAUSE DEATH, PERSONAL INJURY AND PROPERTY DAMAGE.

This document and other information from Parker Hannifin Corporation, its subsidiaries and authorized distributors provide product and/or system options for further investigation by users having technical expertise. It is important that you analyze all aspects of your application including consequences of any failure, and review the information concerning the product or system in the current product catalog. Due to the variety of operating conditions and applications for these products or systems, the user, through its own analysis and testing, is solely responsible for making the final selection of the products and systems and assuring that all performance, safety and warning requirements of the application are met.

The products described herein, including without limitation, product features, specifications, designs, availability and pricing, are subject to change by Parker Hannifin Corporation and its subsidiaries at any time without notice.

Offer of Sale

The items described in this document are hereby offered for sale by Parker Hannifin Corporation, its subsidiaries or its authorized distributors. This offer and its acceptance are governed by the provisions stated on the separate page of this document entitled "Offer of Sale".

Table of Contents

Sources of Contamination.....2-4

Purification Technologies 5

Quality Standards..... 6

Purity Levels 7

Bulk Liquid Separators – P3TF Series.....8-10

Refrigeration Air Dryers – PRD 11-15

Mini Disposable Inline Desiccant Dryer – DD10..... 16

DD Series Inline Desiccant Dryers..... 17-18

Regenerative Desiccant Dryers – DAS 19-23

Heatless Desiccant Air Dryers.....24-27

Automatic Electrical Drain Valve – WDV3-G..... 28

Zero Air Loss Condensate Drain – ED..... 29

Safety Guide.....30-31

Offer of Sale 32

Together, we can separate the good from the bad.



Sources of Contamination

Compressed air and its purification from generation to application

Compressed air is an essential power source that is widely used throughout industry. This safe, powerful and reliable utility can be the most important part of your production process. However, your compressed air will contain water, dirt, wear particles and even degraded lubricating oil which all mix together to form an unwanted condensate. This condensate often acidic, rapidly wears tools and pneumatic machinery, blocks valves and orifices causing high maintenance and costly air leaks. It also corrodes piping systems and can bring your production process to an extremely expensive standstill!

The quality of air required throughout a typical compressed air system can vary.

It is highly recommended that the compressed air is treated prior to entry into the distribution system as well as at each usage point or application.

This approach to system design provides the most cost effective solution to system purification

as it not only removes the contamination already in the distribution system, it ensures that only the most critical areas receive air treated to the highest level.

In many instances the compressed air system will be supplying air to more than one application and although the purification equipment specified in the compressor room would remain unchanged, the point of use protection will vary depending upon the air quality requirements of each application.

In many cases this action alone is not enough, as modern production systems and processes demand an even higher level of air quality. Where required, "point of use" filtration, refrigeration or desiccant air dryers can provide the correct air quality, without the need for drying the complete compressed air installation, which can be both costly and totally unnecessary.

Sources of contamination found in a compressed air system

Contaminants in a compressed air system can generally be attributed to the following:

The quality of air being drawn into the compressor

Air compressors draw in a large volume of air from the surrounding atmosphere containing large numbers of airborne contaminants.

The type and operation of the air compressor

The air compressor itself can also add contamination, from wear particles to coolants and lubricants.

Compressed air storage devices and distribution systems

The air receiver and system piping are designed to store and distribute the compressed air. As a consequence, they will also store the large amounts of contaminants drawn into the system.

Additionally, piping and air receivers will also cool the moist compressed air forming condensate which causes damage and corrosion.

Sources of Contamination

Types of contamination found in a compressed air system

Atmospheric dirt

Atmospheric air in an industrial environment typically contains 183 million per yd³ (140 million per m³) of dirt particles. 80% of these particles are less than 2 microns in size and are too small to be captured by the compressor intake filter, therefore passing directly into the compressed air system.

Water vapor, condensed water and water aerosols

Atmospheric air contains water vapor (water in a gaseous form). The ability of compressed air to hold water vapor is dependent upon its temperature. The higher the temperature, the more water vapor that can be held by the air. During compression, the air temperature is increased significantly, which allows it to easily retain the incoming moisture. After the compression stage, air is normally cooled to a usable temperature. This reduces the air's ability to retain water vapor, resulting in a proportion of the water vapor being condensed into liquid water which is removed by a condensate drain fitted to the compressor after-cooler. The air leaving the after-cooler is now 100% saturated with water vapor and any further cooling of the air will result in more water vapor condensing into liquid water. Condensation occurs at various stages throughout the system as the air is cooled further by the air receiver, piping and the expansion of valves, cylinders, tools and machinery. The condensed water and water aerosols cause corrosion to the storage and distribution system, damage production equipment and the end product. It also reduces production efficiency and increases maintenance costs. Water in any form must be removed to enable the system to run correctly and efficiently.

Rust and pipscale

Rust and pipscale can be found in air receivers and the piping of "wet systems" (systems without adequate purification equipment) or systems which were operated "wet" prior to purification being installed. Over time, this contamination breaks away to cause damage or blockage in production which can also contaminate final product and processes.

Micro-organisms

Bacteria and viruses will also be drawn into the compressed air system through the compressor intake and warm, moist air provides an ideal environment for the growth of micro-organisms. If only a few micro-organisms were to enter a clean environment, a sterile process or production system, enormous damage could be caused that not only diminishes product quality, but may even render a product entirely unfit for use and subject to recall.

Liquid oil and oil aerosols

Most air compressors use oil in the compression stage for sealing, lubrication and cooling. During operation, lubricating oil is carried over into the compressed air system as liquid oil and aerosols. This oil mixes with water vapor in the air and is often very acidic, causing damage to the compressed air storage and distribution system, production equipment and final product.

Oil vapor

In addition to dirt and water vapor, atmospheric air also contains oil in the form of unburned hydrocarbons. The unburned hydrocarbons drawn into the compressor intake as well as vaporized oil from the compression stage of a lubricated compressor will carry over into a compressed air system where it can cool and condense, causing the same contamination issues as liquid oil.

Sources of Contamination

Up to 99% of the total liquid contamination found in a compressed air system is water.

Oil is perceived to cause the most problems as it is seen emanating from open drain points and exhausting valves, however, in the majority of instances, it is actually oily condensate (oil mixed with water) that is being observed.

How much water can be found in a typical compressed air system?

The amount of water in a compressed air system is staggering. A small 100 SCFM (2.8m³/min) compressor and refrigeration dryer combination, operating for 4,000 hours in typical climatic conditions can produce approximately 2,200 gallons (8,328 liters) of liquid condensate per year.

If the compressor is oil lubricated with a typical 2ppm (2 mg/m³) oil carryover, then although the resulting condensate would visually resemble oil, oil would in fact account for less than 0.1% of the overall volume and it is this resemblance to oil to which a false association is made.

The example above assumes uses a small compressor to highlight the large volume of condensate produced. If a compressed air system was operated in warmer, more humid climates, or with larger compressors installed, running for longer periods, the volume of condensate would increase significantly.

Contamination and types of compressors

It is often believed that the level of compressed air purification equipment required in a system is dependent upon the type of compressor used. Contamination in a compressed air system originates from many sources and is not related solely to the compressor or it's lubricants. No matter what compressor type is selected, adequate filtration and separation products will be required to remove the large volume of dirty contaminated water as well as the dirt, rust, pipescale and microbiological contamination in the system.

Preventative maintenance provides you with the following benefits:

- **Lowest operating costs**
- **Superior compressed air quality**
- **Continued protection of downstream equipment and processes**
- **Peace of mind**

Purification Technologies

Compressed air and it's purification

Having identified the different types of contamination that can be found within a compressed air system, we can now examine the purification technologies available for it's removal.

Particle and coalescing filters

Coalescing filters are probably the most important items of purification equipment in any compressed air system. They are designed to remove oil and water aerosols using mechanical filtration techniques and have the additional benefit of removing solid particulate to very low levels (as small as 0.01micron in size). Installed in pairs, most users believe one to be an oil removal filter and the other to be a particulate filter, when in fact, the pair of filters both perform the same function. The first filter, a general purpose filter is used to protect the high efficiency filter against bulk contamination. This "dual filter" installation ensures a continuous supply of high quality compressed air with low operational costs and minimal maintenance time.

Bulk liquid removal high efficiency water separators

Used to protect filters in systems where excessive cooling takes place in distribution piping. Water Separators will remove in excess of 98% of bulk liquid contamination through centrifugal separation techniques.

Refrigeration dryers

Refrigeration dryers work by cooling the air, so are limited to positive pressure dewpoint ratings to prevent freezing of the condensed liquid. Ideal for general purpose applications, they typically provide pressure dewpoints of 38°F (3°C), 45°F (7°C) or 50°F (10°C) pdp. Air is reheated before it re-enters the system to prevent piping from "sweating" in humid conditions. Refrigeration dryers are not suitable for installations where piping is installed in ambient temperatures below the dryer dewpoint i.e. systems with external piping.

Adsorption (desiccant) dryers

Water vapor is water in a gaseous form and is removed from compressed air using a dryer, with dryer performance being measured as pressure dewpoint. Adsorption or desiccant dryers remove moisture by passing air over a regenerative adsorbent material which strips the moisture from the air. This type of dryer is extremely efficient and typical pressure dewpoint ratings are -40°F (-40°C) or -100°F (-70°C) pdp. This means that for water vapor to condense into a liquid, the air temperature would have to drop below -40°F (-40°C) to -100°F (-70°C) respectively (the actual air temperature after an adsorption dryer is not the same as it's dewpoint).

Beneficially, a pressure dewpoint of -15°F (-26°C) or better will not only prevent corrosion, but will also inhibit the growth of microorganisms within the compressed air system.

Important note regarding compressed air dryers

As adsorption and refrigeration dryers are designed to remove only water vapor and not water in a liquid form, they require the use of particulate and coalescing filters, and possibly a bulk liquid separator to work efficiently.

NOTE: For filter product ordering & specifications, please reference catalog: Parker 0700P, PDN1000US or Watts 0305

Quality Standards

Compressed air quality standards – ISO 8573

ISO 8573 is the group of International standards relating to the quality of compressed air and consists of nine separate parts. Part 1 specifies the quality requirements of the compressed air and parts 2 - 9 specify the methods of testing for a range of contaminants.

ISO 8573.1 : 2010 is the primary document used from the ISO 8573 series and it is this document which allows the user to specify the air quality or purity required at key points in a compressed air system.

ISO8573-1 lists the main contaminants as Solid Particulate, Water and oil. The purity levels for each contaminant are shown in separate tables, however for ease of use, this document combines all three contaminants into one easy to use table.

ISO8573-1:2010 Class	Solid Particulate			Concentration mg/m ³	Water		Oil Total oil (aerosol, liquid and vapor) ppm (mg/m ³)
	Maximum number of particles per m ³				Vapor	Liquid	
	0.1 - 0.5 micron	0.5 - 1 micron	1 - 5 micron		Pressure Dewpoint	g/m ³	
0	As specified by the equipment user or supplier and more stringent than Class 1						
1	≤ 20,000	≤ 400	≤ 10	—	≤ -94°F (-70°C)	—	0.008 (0.01)
2	≤ 400,000	≤ 6,000	≤ 100	—	≤ -40°F (-40°C)	—	0.08 (0.1)
3	—	≤ 90,000	≤ 1,000	—	≤ -4°F (-20°C)	—	0.83 (1)
4	—	—	≤ 10,000	—	≤ 37°F (3°C)	—	4.2 (5)
5	—	—	≤ 100,000	—	≤ 45°F (7°C)	—	—
6	—	—	—	≤ 5	≤ 50F (10°C)	—	—
7	—	—	—	5 - 10	—	≤ 0.5	—
8	—	—	—	—	—	0.5 - 5	—
9	—	—	—	—	—	5 - 10	—
X	—	—	—	≤ 10	—	≤ 10	≤ 10

Specifying air purity in accordance with ISO 8573-1:2010

When specifying the purity of air required, the standard must always be referenced, followed by the purity class selected for each contaminant (a different purity class can be selected for each contaminant if required). An example of how to write an air quality specification is shown below:

Example:

ISO 8573-1:2010 Class 1.2.1

ISO8573-1:2010 refers to the standard document and its revision, the three digits refer to the purity classifications selected for solid particulate, water and total oil. Selecting an air purity class of 1.2.1 would specify the following air quality when operating at the standard’s reference conditions:

Class 1, Particulate

In each cubic meter of compressed air, the particulate count should not exceed 20,000 particles in the 0.1 - 0.5 micron size range, 400 particles in the 0.5 - 1 micron size range and 10 particles in the 1 - 5 micron size range.

Class 2, Water

A pressure dewpoint (PDP) of -40°F (-40°C) or better is required and no liquid water is allowed.

Class 2, Oil

In each cubic meter of compressed air, not more than 0.01mg of oil is allowed. This is a total level for liquid oil, oil aerosol and oil vapor.

Cost effective system design

To achieve the stringent air quality levels required for today’s modern production facilities, a careful approach to system design, commissioning and operation must be employed.

Treatment at one point alone is not enough and it is highly recommended that the compressed air is treated in the compressor room to a level that will provide general purpose air to the site and also protect the distribution piping.

Point of use purification should also be employed, not only to remove any contamination remaining in the distribution system, but also with specific attention on the quality of air required by each application. This approach to system design ensures that air is not “over treated” and provides the most cost effective solution to high quality compressed air.



Purity Level

General purpose oil free air

Bulk contamination is removed to an adequate level prior to the air entering the distribution system. Point of use particulate filter(s) are used for removal of contamination within the distribution system. Point of use adsorption dryer installed where lower dewpoints are required.

Typical applications

- Plant automation
- Air logistics
- Pneumatic tools
- General instrumentation
- Air conveying
- Air motors
- Temperature control systems
- Blow guns
- Gauging equipment
- Raw material mixing
- Sand / bead blasting

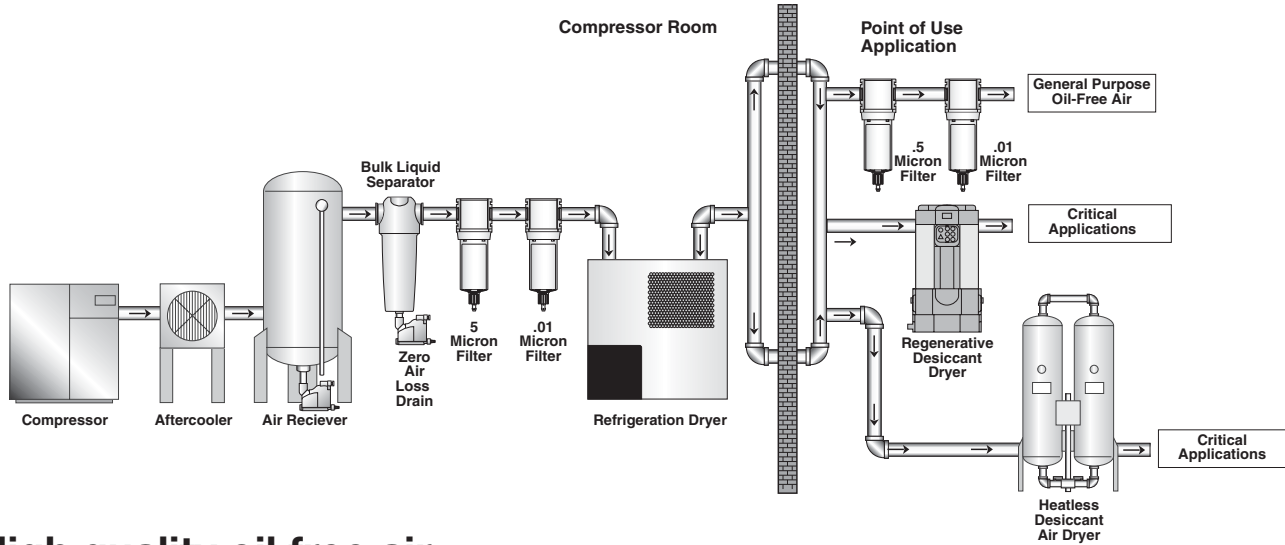

High quality oil free air

Bulk contamination is removed to an adequate level prior to the air entering the distribution system. Point of use particulate filter(s) are used for removal of contamination within the distribution system. Adsorption dryers are used for critical applications where lower dewpoints are required.

Typical applications

- Blow molding of plastics e.g. P.E.T. bottles
- Film processing
- Critical instrumentation
- Advanced pneumatics
- Air blast circuit breakers
- Decompression chambers
- Cosmetic production
- Medical air
- Dental air
- Lasers and optics
- Robotics
- Spray painting
- Air bearings
- Pipeline purging
- Measuring equipment

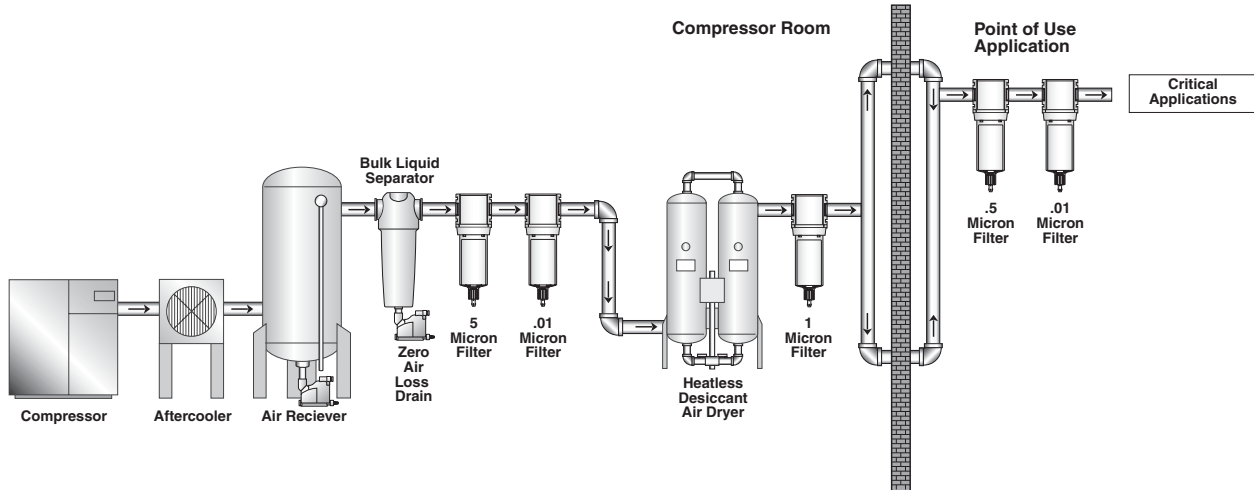

Features

- Tested in accordance with ISO 8573.9
- High liquid removal efficiencies at all flow conditions
- Low pressure losses for low operational costs
- Multiple port sizes for a given flow rate provides increased flexibility during installation
- Suitable for variable flow compressors
- Works with all types of compressor and compressor condensate
- Low maintenance
- Lightweight cast aluminum housing with 1/4" to 3" ports
- External surface epoxy painted for maximum corrosion resistance



Applications

- Bulk liquid removal at any point in a compressed air system
- Protection of refrigeration and heatless regenerative desiccant dryers
- Liquid removal from compressor Inter-coolers / after-coolers
- Liquid separation within refrigeration dryers
- Pre-filtration

Operating information

	P3TF (Bulk Liquid Separator)
Operating pressure	232 PSIG (16 bar) Max
Operating temperature	35°F to 176°F (1.5°C to 80°C)
For technical information see CD	

Flow

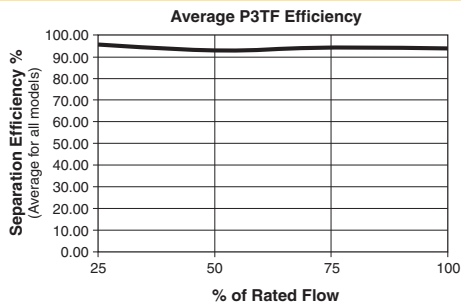

Material specifications

Description	P3TF (Bulk Liquid Separator)
Auto float drain	Plastic
Housing / bowl	Aluminum
Seals	Fluorocarbon

Service kits

Drain	EF1
-------	------------

P3TF Bulk Liquid Separator

	Pipe size	Flow SCFM (L/s)	Weight lb. (kg)	Part number (NPT)
P3TF	1/4"	21 (10)	0.9 (0.4)	P3TFA92WAAN
	3/8"	85 (40)	2.2 (1.0)	P3TFA93WBAN
	1/2"	85 (40)	2.2 (1.0)	P3TFA94WCAN
	3/4"	233 (110)	4.8 (2.2)	P3TFA96WDAN
	1"	233 (110)	2.6 (5.7)	P3TFA98WEAN
	1-1/2"	742 (350)	5.3 (11.6)	P3TFA9BVGAN
	2"	742 (350)	5.3 (11.6)	P3TFA9CWHAN
	3"	1695 (800)	12.0 (26.4)	P3TFA9EWKAN



Pressure Differential at Rated Flow ... 1.0 PSID (0.07 bar)

Stated flows are for operation at 102 PSIG (7 bar) with reference to 20°C, 1 bar (a), 0% relative water vapor pressure.

Note: BSPT threads available upon request.

Most popular.

Bulk Liquid Separators

Air Preparation Systems P3TF Series

P3TF (Bulk Liquid Separator)

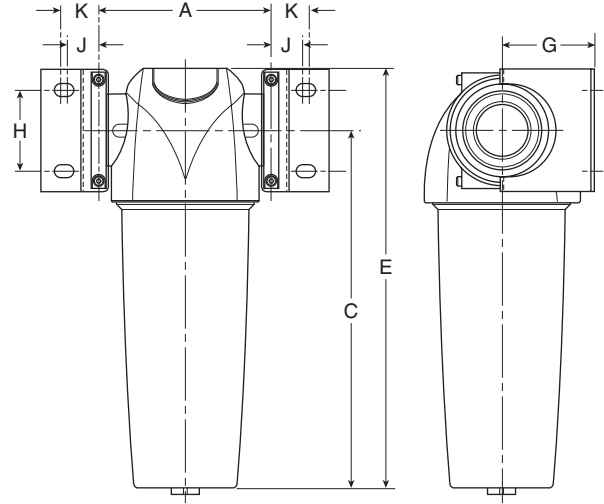
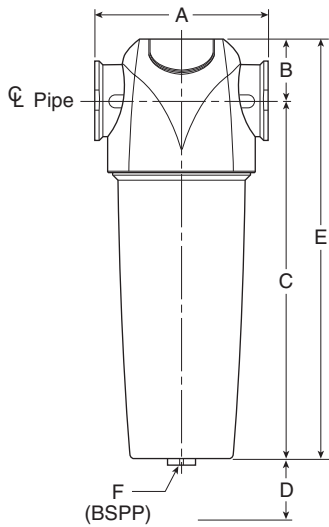

Dimensions

Part number	Pipe size	A	B	C	D	E	BSPP F	G	H	J	K	Wall mounting bracket kit
P3TFA92WAAN	1/4"	3.00 (76)	1.12 (28.5)	6.02 (153)	1.58 (40)	7.15 (181.5)	1/2	2.05 (50)	1.18 (30)	0.71 (18)	0.96 (24.5)	P3TKA00MWA
P3TFA93WBAN	3/8"	3.83 (97.5)	1.34 (34)	7.91 (201)	1.97 (50)	9.25 (235)	1/2	2.36 (60)	1.57 (40)	0.81 (20.5)	1.00 (25.5)	P3TKA00MWB
P3TFA94WCAN	1/2"	3.83 (97.5)	1.34 (34)	7.91 (201)	1.97 (50)	9.25 (235)	1/2	2.36 (60)	1.57 (40)	0.81 (20.5)	1.00 (25.5)	P3TKA00MWB
P3TFA96WDAN	3/4"	5.07 (129)	1.67 (42.5)	13.09 (232.5)	2.76 (70)	10.80 (275)	1/2	2.68 (68)	2.36 (60)	0.91 (23)	1.10 (28)	P3TKA00MWD
P3TFA98WEAN	1	5.07 (129)	1.67 (42.5)	12.68 (322)	2.76 (70)	14.35 (364.5)	1/2	2.68 (68)	2.36 (60)	0.91 (23)	1.10 (28)	P3TKA00MWD
P3TFA9BVGAN	1-1/2"	6.70 (170)	1.97 (50)	18.68 (474.5)	3.94 (100)	20.64 (524.5)	1/2	3.62 (92)	3.31 (84)	1.26 (32)	1.54 (39)	P3TKA00MWF
P3TFA9CWHAN	2"	6.70 (170)	1.97 (50)	18.68 (474.5)	3.94 (100)	20.64 (524.5)	1/2	3.62 (92)	3.31 (84)	1.26 (32)	1.54 (39)	P3TKA00MWF
P3TFA9EWKAN	3"	8.07 (205)	2.36 (60)	30.39 (772)	4.72 (120)	32.76 (832)	1/2	5.31 (135)	3.94 (100)	1.40 (35.5)	1.67 (42.5)	P3TKA00MWJ

Inches (mm)



Wall Mounting Bracket Kit

Mounting brackets provide additional support to filters installed in flexible piping systems or OEM equipment.

For External Drains, please reference WDV3-G Automatic Electrical Drain or ED Zero Loss Drain.



Bulk Liquid Separators

Designed in accordance with ASME and CRN

Connection sizes: 4 inch & 6 inch

High liquid removal efficiencies at all flow conditions

Suitable for variable flow compressors

Works with all types of compressor and compressor condensate

External surface epoxy painted for maximum corrosion resistance

Material specifications

Baffle	Plated steel
Body	Steel
Deflector	Plated steel
Seals	Fluorocarbon
Stud	Plated steel

Air Preparation Products P3TF Series Bulk Liquid Separators



P3TF Series

Operating information

P3TF Series	
Operating Pressure:	232 PSIG (16 bar)
Operating Temperature:	35°F to 150°F (1.5°C to 66°C)

Inlet air pressure correction

For pressures above 232 PSIG (16 bar), use manual drain.

PSI	15	29	44	58	73	87	100	116	131	145	160	174	189	203	218	232	247	261	275	290
bar	1	2	3	4	5	6	7	8	9	10	11	12	13	14	15	16	17	18	19	20
Factor	2.65	1.87	1.53	1.32	1.18	1.08	1.00	0.94	0.88	0.84	0.80	0.76	0.73	0.71	0.68	0.66	0.64	0.62	0.61	0.59

Bulk Liquid Separators

	Port size	Flow SCFM	Element type	Number of elements	Part number
	4" Flange	2119	0.01 micron	4	P3TFAFFW2AN
	6" Flange	3814	1.0 micron	6	P3TFAFGW3AN

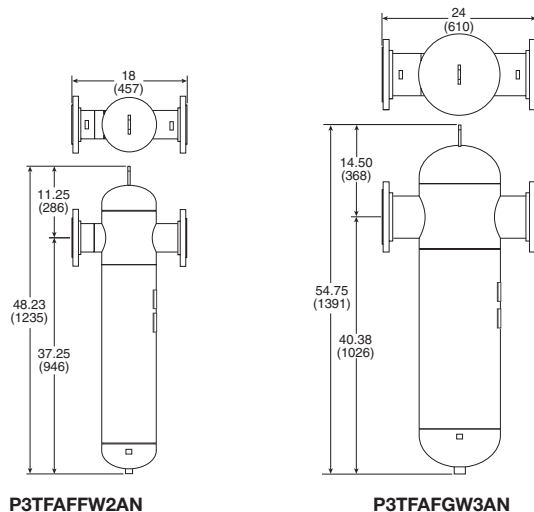

P3TFAFFW2AN

P3TFAFGW3AN

Most popular.

Service kits

Description	P3TF Series
DP gauge replacement kit	DPG-Kit
Drain kit - 1/2" NPT	HDF-120-NPT-A

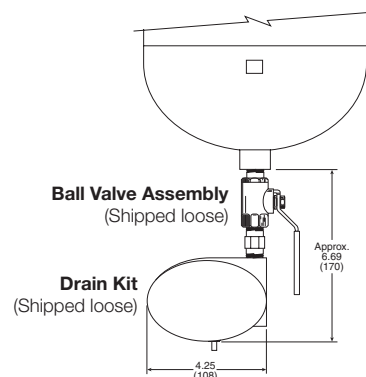

What is refrigeration drying?

The use of refrigeration drying for compressed air treatment is tested and proven for many industrial applications. Dewpoints of 35°F (1.7°C) to 50°F (10°C) are suitable for many indoor applications where a general removal of bulk water and some vapor is sufficient for the end user's process.

Refrigeration dryers use a set of heat exchangers or a single heat exchanger (with chambers) first to pre-cool the air; second, to refrigerate the air to condense out moisture vapor; and last, to re-heat the air to prevent pipe sweating downstream. Direct Expansion dryers are a type of dryer where the compressed air and the refrigerant come into direct contact via the heat exchanger. While reliable and simple to use, they generally require that the unit continue to run regardless of actual compressed air flow through the dryer. Cycling dryers utilize a thermal mass as the means to absorb the heat from the compressed air. By chilling a thermal mass, a refrigerant compressor may turn off in times of low demand thereby saving energy by shutting off the refrigerant compressor. There is, however, an additional heat transfer (the thermal mass), so a small amount of additional cost may or may not offset the amount of money saved by shutting off the compressor.

The use of refrigeration dryers is preferred:

- In the capacity range of 10 SCFM (17 Nm³/hr) to 2,400 SCFM (4078 Nm³/hr)
- Inlet temperatures to 120°F (48.9°C)
- Wide ranges of operating pressures
- Indoor applications
- System with fluctuating conditions and demand

Refrigeration Air Dryers



PRD10 - PRD250

- “Plug & play” design for easy installation and operation (PRD10 - PRD125)
- Small space saving design
- Oversized demister separator resulting in excellent liquid removal over all operating conditions
- Low pressure differential across the dryer (1.45 PSIG average)
- Oversized condenser to operate in ambients to 122°F (50°C)
- All models incorporate a dewpoint indicator

PRD325 - PRD2400

- Optimum dewpoint levels for highest system performance
- Advanced patented design solutions
- High reliability, easy to use and maintain
- Unique 4-in-1 SmartPack heat exchanger
- Integral drain
- Extremely low pressure drop design
- SmartControl energy saving function
- Excellent dewpoint performances
- Advanced compliant scroll compressor

PRD Series

Capacity CFM @ 100 PSIG (m ³ /min @ 6.9 bar)	Primary voltage	Part number	Pipe size	Recommended filtration		
				Bulk separator	Pre-filter (5µ particulate)*	Post-filter (.01µ coalescing)
10 (17)	115V/1ph/60Hz	PRD10-115160	1/2" NPT-F	P3TFA94WCAN	P32FA94ESAN	P32FA94DSAN
15 (26)	115V/1ph/60Hz	PRD15-115160	1/2" NPT-F	P3TFA94WCAN	P32FA94ESAN	P32FA94DSAN
25 (43)	115V/1ph/60Hz	PRD25-115160	1/2" NPT-F	P3TFA94WCAN	P32FA94ESAN	P32FA94DSAN
35 (60)	115V/1ph/60Hz	PRD35-115160	1/2" NPT-F	P3TFA94WCAN	P32FA94ESAN	P32FA94DSAN
50 (85)	115V/1ph/60Hz	PRD50-115160	3/4" NPT-F	P3TFA96WDAN	P33FA96ESAN	P33FA96DSAN
75 (127)	115V/1ph/60Hz	PRD75-115160	3/4" NPT-F	P3TFA96WDAN	P33FA96ESAN	P33FA96DSAN
100 (170)	115V/1ph/60Hz	PRD100-115160	3/4" NPT-F	P3TFA96WDAN	P3NFA96ESA	P3NFA96DSA
125 (212)	115V/1ph/60Hz & 230V/1ph/60Hz	PRD125-115160 PRD125-230160	1-1/2" NPT-F	P3TFA9BWGAN	P3NFA9PESA	P3NFA9PDSA
150 (255)	115V/1ph/60Hz & 230V/1ph/60Hz	PRD150-115160 PRD150-230160	1-1/2" NPT-F	P3TFA9BWGAN	P3NFA9PESA	P3NFA9PDSA
175 (297)	115V/1ph/60Hz	PRD175-230160	1-1/2" NPT-F	P3TFA9BWGAN	35F77BAP	35F77EAP
200 (425)	230V/1ph/60Hz	PRD200-230160	1-1/2" NPT-F	P3TFA9BWGAN	35F77BAP	35F77EAP
250 (425)	230V/3ph/60Hz & 460V/3ph/60Hz	PRD250-230360 PRD250-460360	1-1/2" NPT-F	P3TFA9BWGAN	35F77BAP	35F77EAP
325 (552)	230V/3ph/60Hz & 460V/3ph/60Hz	PRD325-230360 PRD325-460360	2" NPT-F	P3TFA9CWHAN	35F87BAP	35F87EAP
400 (680)	230V/3ph/60Hz & 460V/3ph/60Hz	PRD400-230360 PRD400-460360	2" NPT-F	P3TFA9CWHAN	35F87BAP	35F87EAP
500 (849)	230V/3ph/60Hz & 460V/3ph/60Hz	PRD500-230360 PRD500-460360	2" NPT-F	P3TFA9CWHAN	35F87BAP	35F87EAP
700 (1189)	230V/3ph/60Hz & 460V/3ph/60Hz	PRD700-230360 PRD700-460360	3" NPT-M	P3TFA9EWKAN	43FN7BAP	43FN7EAP
800 (1359)	230V/3ph/60Hz & 460V/3ph/60Hz	PRD800-230360 PRD800-460360	3" NPT-M	P3TFA9EWKAN	43FN7BAP	43FN7EAP
1000 (1700)	460V/3ph/60Hz	PRD1000-460360	3" NPT-M	P3TFA9EWKAN	43FN7BAP	43FN7EAP
1200 (2039)	460V/3ph/60Hz	PRD1200-460360	3" NPT-M	P3TFA9EWKAN	43FN7BAP	43FN7EAP
1600 (2718)	460V/3ph/60Hz	PRD1600-460360	4" Flg.	P3TFAFFW2AN	P3TFAFFQ2AN*	P3TFAFFD2AN
2000 (3400)	460V/3ph/60Hz	PRD2000-460360	6" Flg.	P3TFAFGW3AN	P3TFAFGQ3AN*	P3TFAFGD3AN
2400 (4078)	460V/3ph/60Hz	PRD2400-460360	6" Flg.	P3TFAFGW3AN	P3TFAFGQ3AN*	P3TFAFGD3AN

Most popular.

* 1µ coalescing



PlusPack heat exchanger (patent pending)

The revolutionary PlusPack features a 3-in-1 aluminum design with integral air connections. All models include an air-to-air freecooler, while the unique “slowflow” demister ensures perfect dewpoints whatever the operating conditions.

Demister separator

A high capacity demister separator is employed for the removal of condensed liquids. This lowers the air velocity which maximizes the condensate separation from the air, even when the dryer is not operating at maximum flow. This design also ensures the differential pressure across the dryer is kept to a minimum.

Refrigerant condenser

Oversized high efficiency air cooled condenser. Re-positioned to improve reliability and reduce the risk of dirt contamination.

Condensate drain niche

The PRD Refrigeration Dryer range comes standard with a level sensing automatic float drain. Other drains are available upon request. The positioning of the drain niche allows for easy access to the drain without the requirement of removing panels.

Refrigerant compressor

Maintenance free hermetically sealed refrigerant compressor. Low refrigerant charge eliminates the requirement for pre-heating on start up & prevents any liquid refrigerant returns.



Assured quality & performance

Every dryer undergoes sophisticated testing, including dewpoint tests with compressed air flow. Multiple helium leak testing, again on every dryer, ensures years of trouble-free operation.

Energy efficiency

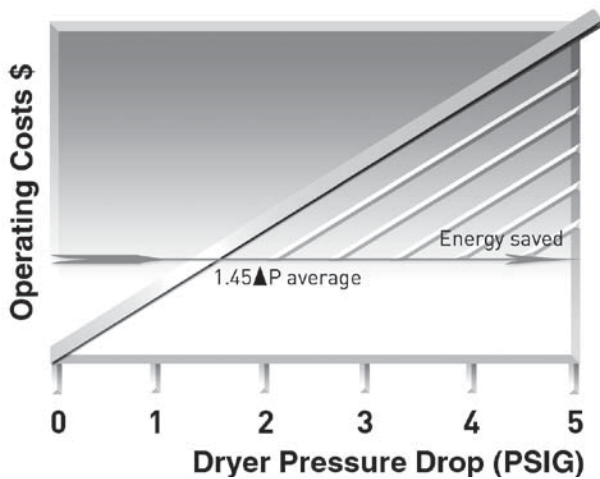

Poorly constructed heat exchangers and liquid separators create a high pressure differential across the dryer which leads to high operational costs and poor dewpoint performance.

The PRD dryer range utilizes advanced heat exchanger and demister separation technology and delivers uncompromising performance at the lowest cost of ownership.

Moisture separation technology

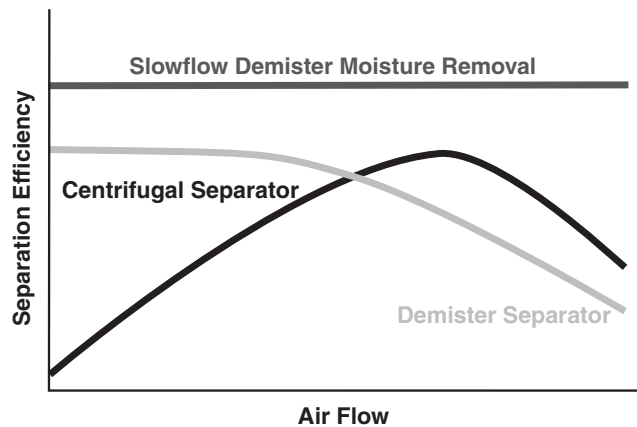

The oversized “slowflow” demister is non-velocity sensitive and therefore offers excellent liquid separation whatever the airflow.

The importance of compressed air as a provider of energy for modern industrial processes is widely known. What is often overlooked however is the need to provide quality treatment for this air.

In fact, the air entering the system contains condensate which, when cooled, will turn into liquid water, causing extensive damage not only to the compressed air network, but also to the finished product.

PRD refrigeration dryers actively remove this condensate to achieve extremely dry compressed air.

Our SmartPack heat exchanger offers minimal pressure drops and class leading performance, and significantly increases the efficiency of the whole compressed air treatment process. The innovative SmartControl function automatically and continuously adjusts dryer operation to the effective working conditions, minimizing operating costs and maximizing performances.

Compressed air purification equipment must deliver uncompromising performance and reliability while providing the right balance of air quality with the lowest cost of operation. Many manufacturers offer products for the filtration and purification of contaminated compressed air, which are often selected only upon their initial purchase cost, with little or no regard for the air quality they provide, the cost of operation throughout their life or their environmental impact. When purchasing purification equipment, delivered air quality, the overall cost of ownership and the equipment's environmental impact must always be considered.



Smart technology: the benefits

SmartPack heat exchanger provides less than 2 PSI pressure drop

The SmartPack (patent pending) heat exchanger features an extremely robust, all-in-one aluminum design, with no interconnecting tubing.

The geometry of the heat exchanger has been designed in order to optimize its performances. In particular, large volumes allow low air velocity through the heat exchanger section, resulting in high exchange efficiency and low pressure drops. Pressure drops are further improved thanks to the absence of interconnecting pipes through the different sections of the heat exchanger and to a straight forward path of the compressed air flow with smooth and minimum changes of flow directions.

Smart BMS interface

Simple BMS interface includes:

- RS485 serial card provides direct communication to Modbus. Requires no gateway or A.N.I.
- Provides visualization of dewpoint, alarm conditions and service indication.
- Provides remote control of the dryer including on/off and alarm reset (depending on actual alarm)

SmartDrain - Dual mode zero air loss drain

The drainage chamber is integrated into the heat exchanger while the valve mechanism is fitted in an easily accessible drain niche. The SmartDrain continuously adjusts itself to the actual working conditions, ensuring zero air loss and a notable reduction in system power consumption.

An innovative control system continuously monitors for fault situations. If a fault does occur, an alarm is signaled and the drain switches to conventional timed solenoid drain operation. The dual mode circuitry ensures maximum reliability.

Smart control with SmartSave cycling

The multifunction SmartControl provides a versatile platform for user interface and SmartSave Cycling (if enabled). The innovative SmartSave (patent pending)

Cycling Control continuously monitors the demand placed on the dryer. At conditions of low demand the refrigerant compressor is cycled off to save energy. A sophisticated algorithm continuously adapts the operation of the dryer for optimum energy efficiency while minimizing the dewpoint spikes common to traditional thermal mass dryers.

Compliant scroll compressors

These units feature Compliant Scroll compressors, offering energy savings of 20 -30% when compared with piston compressors. The ability to tolerate liquid returns coupled with 50% less moving parts render them nearly indestructible and highly reliable. Low vibration levels increase overall refrigeration circuit

Operating information		PRD10-PRD175	PRD200-PRD250	PRD325-PRD2400
Temperature	Ambient (maximum)	122°F (50°C)	122°F (50°C)	122°F (50°C)
	Ambient (minimum)	41°F (5°C)	41°F (5°C)	41°F (5°C)
	Inlet (maximum)	149°F (65°C)	140°F (60°C)	140°F (60°C)
Pressure (maximum)		232 PSIG (16 bar)	203 PSIG (14 bar)	203 PSIG (14 bar)
Refrigerant		R134a	R407C	R407C

Flow correction factors Capacities are based upon:
 Ambient temperature - 100°F (38°C); Inlet temperature - 100°F (38°C);
 and Working pressure - 100 PSIG (7 bar g).

To obtain dryer capacity at new conditions, multiply nominal capacity x C1 x C2 x C3

	PRD10 - PRD175								PRD200 - PRD250							PRD325 - PRD2400							
Ambient temperature (C1)																							
°F	60	70	80	89	100	110	120		70	80	90	100	110	120	122		90	100	110	120	122		
°C	16	21	27	32	38	43	49		21	27	32	38	43	49	50		32	38	43	49	50		
Factor	1.34	1.26	1.17	1.09	1.00	0.91	0.82		1.22	1.15	1.05	1.00	0.94	0.79	0.71		1.05	1.00	0.94	0.79	0.71		
Inlet temperature (C2)																							
°F	90	100	110	120	140	149			90	100	110	120	130	140			90	100	110	120	130	140	
°C	32	38	43	49	60	65			32	38	43	49	54	60			32	38	43	49	54	60	
Factor	1.24	1.00	0.81	0.67	0.45	0.43			1.24	1.00	0.82	0.68	0.56	0.40			1.22	1.00	0.82	0.68	0.56	0.46	
Inlet pressure (C3)																							
PSIG	60	80	100	125	150	175	200	230	50	80	100	125	150	174	203		50	80	100	125	150	174	203
bar	4	6	7	9	10	12	14	16	3	6	7	9	10	12	14		3	6	7	9	10	12	14
Factor	0.83	0.93	1.00	1.07	1.12	1.16	1.19	1.22	0.77	0.93	1.00	1.07	1.12	1.15	1.18		0.77	0.93	1.00	1.07	1.12	1.15	1.18

Dimensions

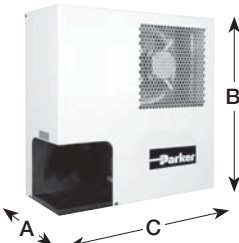
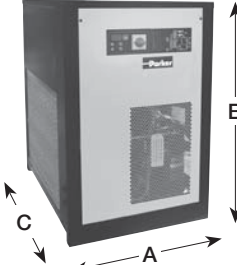
	Model number	A	B	C	Weight (kg)
 <p>PRD10-PRD250</p>	PRD10	8.3 (210)	17 (430)	17.7 (450)	42 (19)
	PRD15	8.3 (210)	17 (430)	17.7 (450)	42 (19)
	PRD25	8.3 (210)	19.9 (505)	19.7 (500)	52 (24)
	PRD35	8.3 (210)	19.9 (505)	19.7 (500)	52 (24)
	PRD50	8.9 (225)	22.3 (565)	20.5 (520)	58 (27)
	PRD75	8.9 (225)	22.3 (565)	20.5 (520)	68 (31)
	PRD100	8.9 (225)	22.3 (565)	20.5 (520)	77 (35)
	PRD125	16.7 (425)	23.8 (605)	21.8 (555)	115 (52)
	PRD150	16.7 (425)	23.8 (605)	21.8 (555)	128 (58)
	PRD175	16.7 (425)	23.8 (605)	21.8 (555)	132 (60)
	PRD200	28.0 (711)	37.0 (940)	22.0 (559)	183 (83)
	PRD250	28.0 (711)	42.0 (1067)	41.0 (1041)	287 (130)
 <p>PRD325-PRD2400</p>	PRD325	28.0 (711)	42.0 (1067)	41.0 (1041)	320 (145)
	PRD400	28.0 (711)	42.0 (1067)	41.0 (1041)	320 (145)
	PRD500	28.0 (711)	42.0 (1067)	41.0 (1041)	342 (155)
	PRD700	32.0 (813)	52.0 (1321)	46.0 (1168)	529 (240)
	PRD800	32.0 (813)	52.0 (1321)	46.0 (1168)	529 (240)
	PRD1000	32.0 (813)	52.0 (1321)	46.0 (1168)	551 (250)
	PRD1200	40.0 (1016)	67.0 (1702)	43.0 (1092)	816 (370)
	PRD1600	40.0 (1016)	68.0 (1727)	71.0 (1803)	1279 (580)
	PRD2000	40.0 (1016)	68.0 (1727)	71.0 (1803)	1477 (670)
	PRD2400	40.0 (1016)	68.0 (1727)	71.0 (1803)	1521 (690)

Inches (mm)

 Most popular.



Mini disposable inline desiccant dryer – DD10

Used at the point-of-use, this disposable, mini inline desiccant dryer removes all traces of water vapor, oil vapor and dirt. It is often used directly upstream of blow guns or spray guns as final protection for critical parts blow off and paint spraying. Install in either direction; it functions in both directions.

A 40 micron, porous bronze element removes fine dirt particles, an oil removing media removes oil vapor, and desiccant beads absorb water vapor. The see-through housing shows desiccant color change from the original orange to a green color in the desiccant beads, which indicates that the dryer needs to be replaced.

Features

- Polycarbonate material allows clear desiccant visibility
- Disposable
- Used for parts blow off
- Protection for paint guns
- Non-toxic desiccant standard

Specifications

Housing	Polycarbonate
Port threads	1/4" NPT
Maximum flow capacity	15 SCFM
Maximum pressure rating	125 PSIG (0 to 8,6 bar)
Maximum temperature rating	130°F (54°C)
Operating temperature rating	32°F to 130°F (0°C to 54°C)
Weight	2.8 oz. (79.4 g)



DD10-02

Installation

The DD10 is equipped with a 1/4" NPT (F) and (M) ports and can be installed in either direction. When installing the filter/dryer hand tighten to a leak proof seal. Do not use any mechanical means to hold the filter/dryer and do not over torque the threads.

Operation

1. The unique feature of the filter/dryer design allows you to visually see when it is time to install a new DD10 by observing the color change from the original dark color to a complete light transparent color in the desiccant beads.
2. Do not attempt to clean the filter/dryer as the use of solvents, ketones, etc., will adversely affect the plastic housing.
3. Keep the hose free of snags. Extra tension on the filter/dryer assembly could break the unit at the connecting ports. To clear stuck hoses, grasp hose below the filter/dryer.

Non-metallic material is highly resistant to chemicals.

See through housing shows color change when dryer needs replacement.

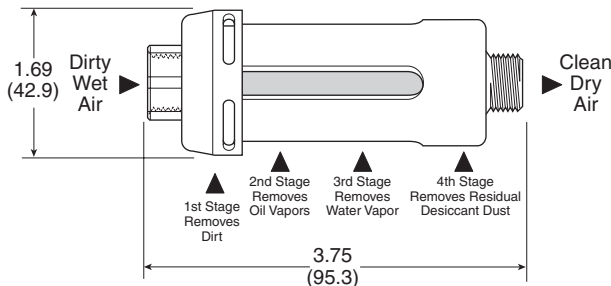

Inline desiccant dryer – DD15, DD30, DD60

Features

- Inline desiccant dryers are a convenient and cost effective means of ensuring your sensitive intermittent pneumatic applications are never exposed to damaging moisture
- Compact size for point-of-use applications
- Drying efficiency down to -40°F pressure dew point
- Easily and quickly serviced
- Sightglass in bowl to monitor desiccant
- Built-in particulate after filter prevents downstream dust
- No electricity needed
- Low pressure drop
- No purge air lost as with other dryer types
- Check valve required on inlet
- Desiccant must be ordered separately



Inline Desiccant Dryers

Port size	Part number SCFM / Desiccant capacity ¹		
	15 SCFM / 2.5 lb.	30 SCFM / 5 lbs.	60 SCFM / 10 lbs.
1/4 ²	DD15-02		
3/8 ²	DD15-03		
1/2 ²	DD15-04	DD30-04	DD60-04
3/4	DD15-06	DD30-06	DD60-06
1		DD30-08	DD60-08

Notes:

1. Desiccant must be ordered separately.
2. These units supplied with reducer bushings.

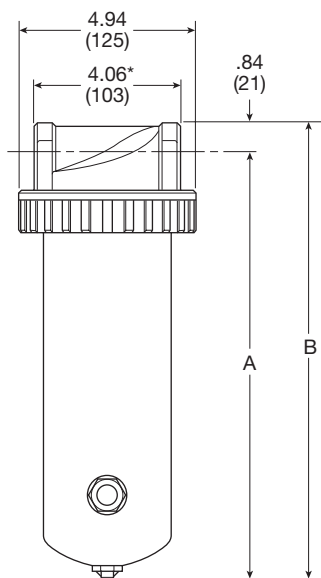

Dimensions

	A	B
DD15	12.69 (322)	13.5 (343)
DD30	22.44 (570)	23.25 (591)
DD60	29.44 (748)	30.25 (768)

* Dimension does not include reducer bushings for 1/4", 3/8", 1/2" versions.

Inches (mm)

Operating information

Optimum working temperature	Below 100°F
Operating temperature	32°F to 180°F (0°C to 82°C)
Operating pressure	0 to 300 PSIG Max (21 bar)

Installation tips

- Always place a moisture separator / particulate filter to remove bulk moisture **and** a coalescing filter to remove oil upstream of desiccant dryer. Desiccant coated with oil will not adsorb oil.
- Automatic drains should be used in prefilters
- A spring ball check valve should be installed at the dryer inlet to maximize the life of the desiccant.

Most popular.

Technical Specifications – DD Series

As the wet compressed air enters through the inlet, the air travels down through the bed of desiccant which adsorb the water vapor and aerosols. The silica gel desiccant beads will reduce the humidity down to a -40°F pressure dew point. After the moisture has been removed, the dry air passes through a sintered bronze filter element (eliminating dust downstream), up the tube and out the outlet port.

As the desiccant becomes saturated with moisture, the dew point will begin to rise. This is evident when the green silica gel desiccant beads in the sight glass change to orange, indicating the need for desiccant replacement. Simply remove the flange and bowl and replace with new desiccant or regenerate saturated desiccant by heating to 275°F.

Air Preparation Systems Inline Desiccant Dryers

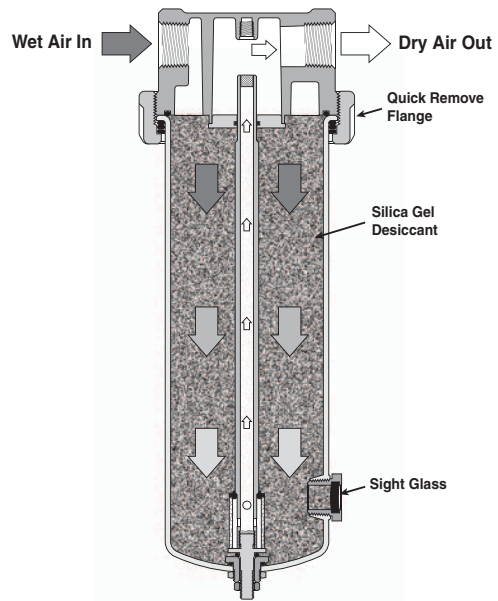

Desiccant dryers kits & accessories

Desiccant - environmentally friendly silica gel 100% Indicating –

DD15	DRP-14-447/003
DD30	DRP-14-447/006
DD60	DRP-14-447/012

Flow tube repair kit (tube, filter element(s), adaptor)

DD15	RKDD15-02-06
DD30	RKDD30-03-08
DD60	RKDD60-03-08

Mounting brackets (Recommended for DD15 & DD30 only) –

1 inch pipe size (pair of pipe mounted brackets)	SA200CW57
--	-----------

Spring check valve for inlet (250 PSIG max.) –

(Maximizes life of desiccant)

1/4 inch NPT.....	003393001
3/8 inch NPT.....	003393002
1/2 inch NPT.....	003393003
3/4 inch NPT.....	003393004

Specifications

Desiccant capacity (desiccant must be ordered separately) –

DD15	2.5 lb.
DD30	5 lb.
DD60	10 lb.

Filter element rating –

DD15, DD30	90 micron
DD60	40 micron

Pressure & temperature ratings –

Optimum working temperature	Below 100° F
Pressure range	0 to 300 PSIG
Temperature range	32°F to 180°F

Weight (housing only) –

DD15 (add 2.5 lb for weight full).....	8 lb. (3.6 kg)
DD30 (add 5 lb for weight full).....	13 lb. (5.9 kg)
DD60 (add 10 lb for weight full).....	20 lb. (9.1 kg)

Materials of construction

Bowl –

DD15, DD30	Aluminum
DD60	Steel

Flow tube

Filter elements

Head & flange ring

Other hardware

Seals

Sight glass

What is adsorption drying?

Drying compressed air through adsorption represents a purely physical process in which water vapor (adsorbate) is bound to the drying medium (adsorbent) through binding forces of molecular adhesion. Adsorbents are solids in spherical and granular form which are permeated by an array of pores. The water vapor is deposited onto the internal and external surface of the adsorption medium, without the formation of chemical compounds taking place, therefore the adsorption medium does not have to be replenished but only periodically regenerated.

Heatless

The layout of adsorption dryers with heatless regeneration is clear and simple. Compared with other adsorption dryer systems, pressure dewpoints down to -100°F (-73°C) can be achieved without additional effort.

Use in the higher pressure ranges and at low inlet temperatures causes the quantity of air needed for desorption to be reduced to an economical value.

At low operating pressure the demand for already dried compressed air for purposes of regeneration is increased.

This increase causes a large proportion of the prepared compressed air to be no longer available for productive purposes.

Depending on the cycle, the quantity of air enclosed in the adsorber expands upon release at regular intervals with an emission noise level of about 90-95dB(A). Given suitable noise attenuation measures, a reduction of the noise emission level to the region of 10-15 dB(A) can be accomplished.

The use of adsorption dryers with heatless regeneration is preferred in the following applications:

- Capacity range of up to 800 SCFM
- Higher pressure ranges
- High inlet temperatures
- Installation in explosion proof areas
- Use under ground portable applications
- Hazardous locations (pneumatic controls)

Regenerative Desiccant Dryers

Features

- Point of use application bringing clean dry air just where you need it.
- Approved to international standards designed in accordance with ASME VIII Div.1, approved to CSA/UL/CRN and fully CE Marked (PED, EMC, LVD) as standard.
- Simple to install - flexible installation utilizing the multiple in-line inlet & outlet connection ports.
- Compact and lightweight - can be floor, bench or wall / canopy mounted.
- Very quiet operation - noise level less than 70dB(A).
- Can be installed almost anywhere, IP66 / NEMA 4 protection as standard.
- Audible alarm - indicating service interval for optimal performance.
- Simple & easy to maintain - due to the quick release top cap arrangement, which does NOT require the inlet / outlet ports to be disconnected as with traditional systems, maintenance can be achieved in under 15 minutes.

The DAS is the reliable, cost effective and flexible way to provide clean dry air exactly where needed.



Operating information

Operating temperature	35°F (1.5°C) min.
Inlet temperature	122°F (50°C) max.
Operating pressure	58 to 175 PSIG (4 to 21 bar)
Flow range	3 SCFM to 20 SCFM @ 100 PSIG (85 L/min to 567 L/min @ 7 bar)
Noise level (Average)	70dB(A)
Pressure dewpoint – Standard	-40°F (-40°C) pdp
Standard electrical supply	115/1ph/60Hz (Tolerance +/- 10%)
Controls	Electronic control timer
Connections	3/8 NPT

Regenerative Desiccant Dryer

	A	Weight (kg)	SCFM	Part number	Maintenance kit	
	16.6 (422)	24.2 (11)	3	DAS1	DASMK1	
	19.7 (500)	28.7 (13)	5	DAS2	DASMK2	
	24.2 (616)	35.3 (16)	8	DAS3	DASMK3	
	27.2 (692)	39.7 (18)	10	DAS4	DASMK4	
	33.3 (847)	44.1 (20)	13	DAS5	DASMK5	
	35.7 (906)	50.7 (23)	15	DAS6	DASMK6	
	43.2 (1098)	61.7 (28)	20	DAS7	DASMK7	

Inches (mm)

Service kits

Description	Part number
Mounting Bracket	
Fixed Wall	DASMB1
45° Tilt Wall	DASMB2

Sizing chart (correction)

Minimum inlet pressure										
	PSIG	58	73	87	100	116	135	145	160	175
	bar g	4	5	6	7	8	9	10	11	12
Maximum inlet temperature										
95°F (35°C)	0.63	0.75	0.88	1.00	0.97	1.08	1.18	1.29	1.40	
104°F (40°C)	0.61	0.73	0.85	0.97	0.94	1.05	1.14	1.25	1.36	
113°F (45°C)	0.55	0.66	0.77	0.88	0.85	0.95	1.04	1.14	1.23	
122°F (50°C)	0.46	0.55	0.64	0.73	0.71	0.79	0.86	0.94	1.02	

Most popular.

Regenerative Desiccant Dryers

Product applications

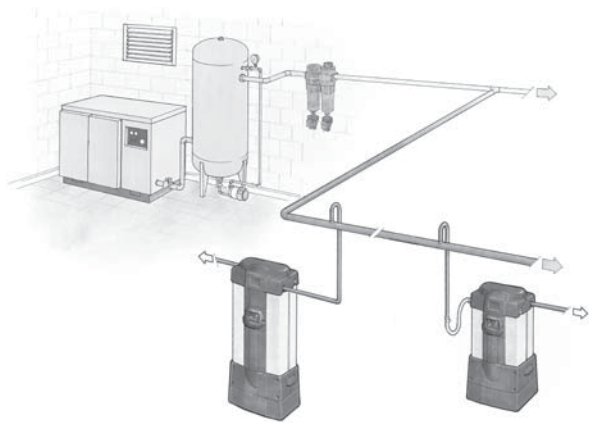

Typical applications:

- Computer numerical control (CNC) machines
- Coordinate measuring machines
- Laboratories
- Lasers
- Packaging machines
- Instrumentation
- Processing equipment
- Conveying machines

The Regenerative Desiccant Dryers will benefit users who have a specific need for Clean Dry Air (CDA) directly after a compressor, or for a particular application where the air is critical to the operating process or end product.

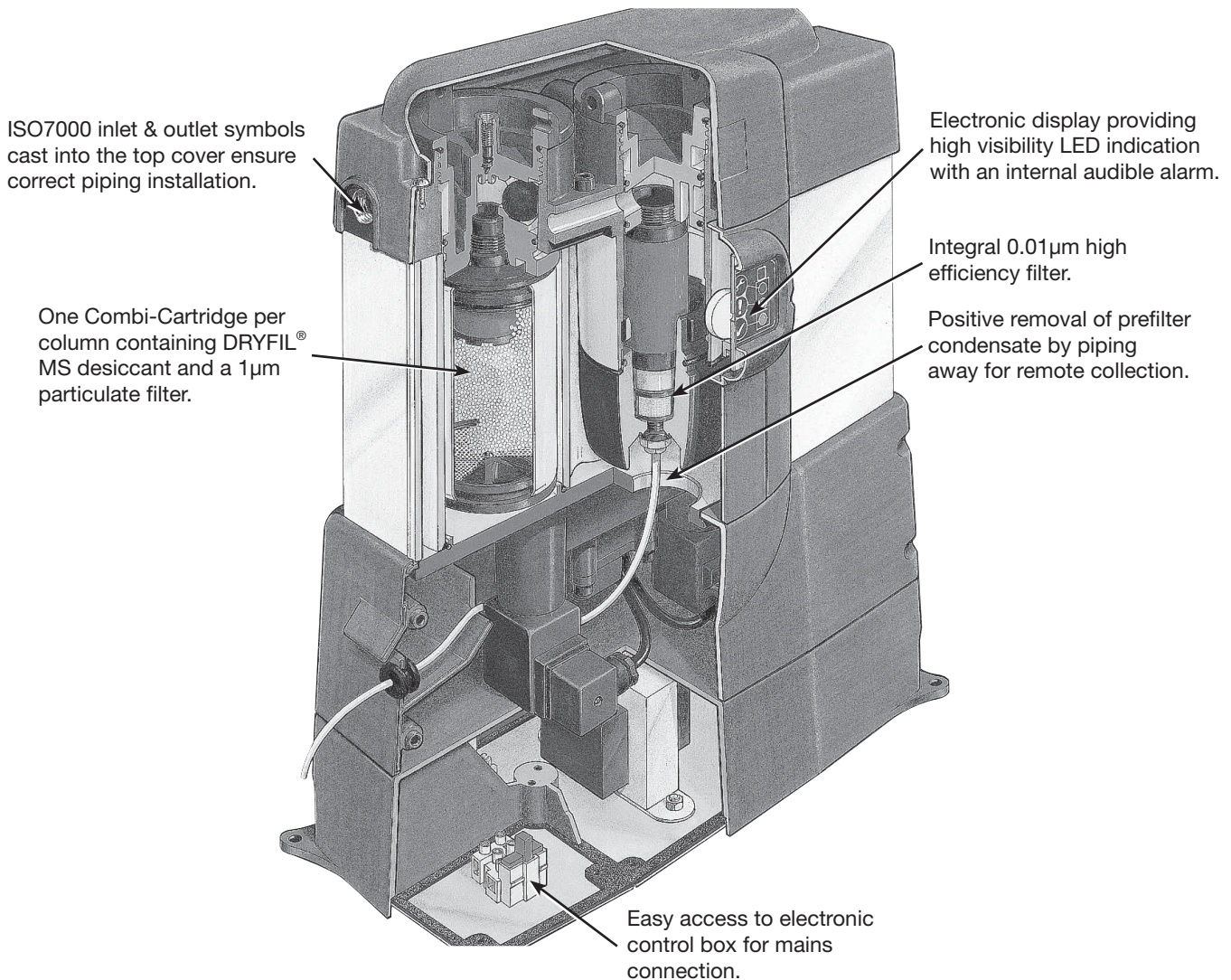

Operation

DAS Series

1 Compressed air enters the integral pre-filter and passes into the left hand chamber (Column A) where the air is dried before passing to the application.

A small amount of dry purge air is used to regenerate the right hand chamber (Column B) which is wet, using the PSA (Pressure Swing Adsorption) method of regeneration, venting the saturated air to atmosphere under pressure. The same regeneration air is also used to “back flush” the integral filter to prolong its working life.

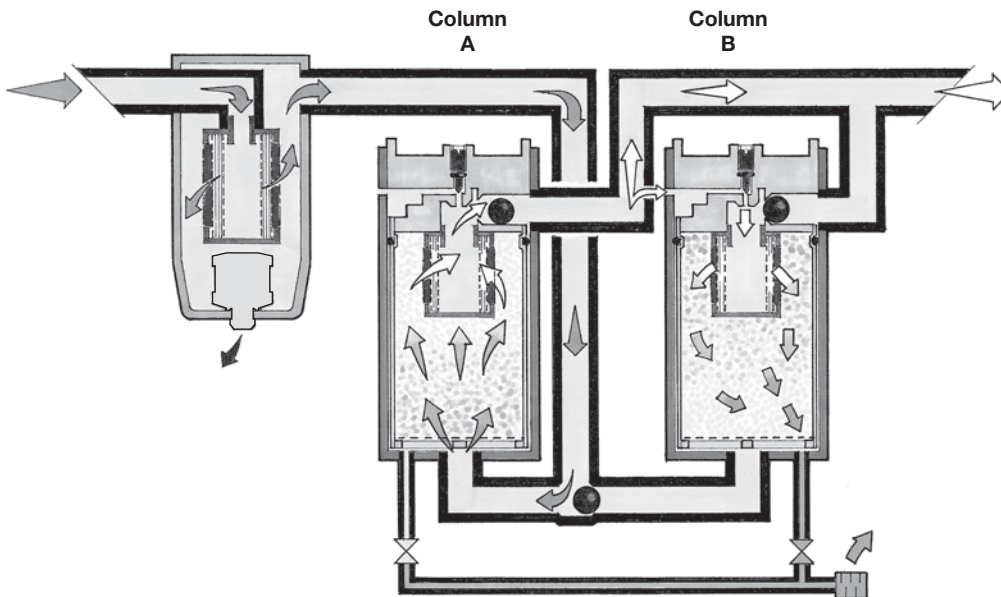

2 Prior to changeover, the right hand chamber (Column B) enters repressurisation where the exhaust.

This process ensures a smooth uninterrupted changeover, preventing the loss of any system pressure, before the process repeats itself.

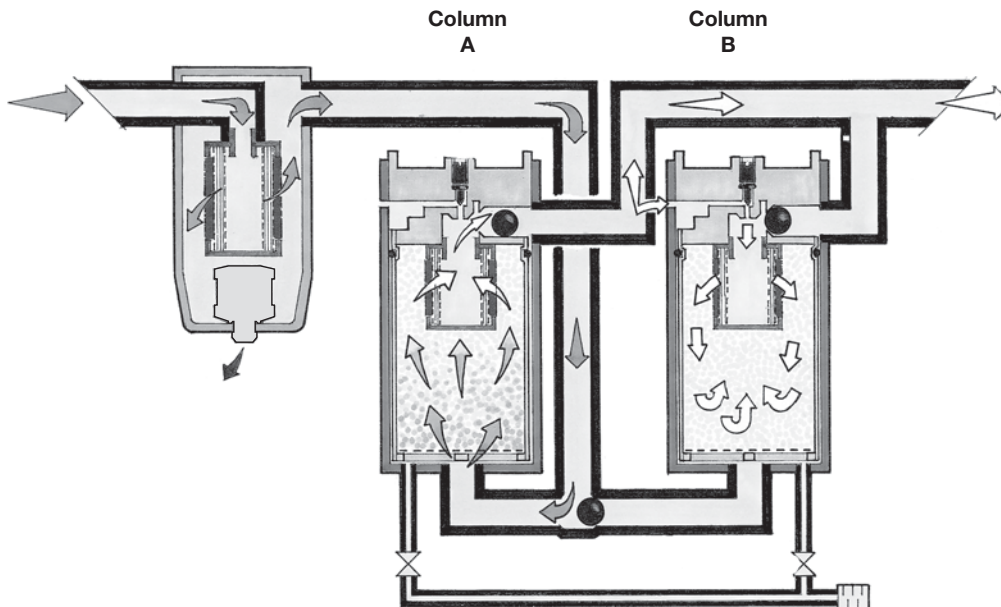

Optional Features

DAS Series

Optional features

- For totally quiet operation, the regeneration exhaust air can be positively piped away.
- Remote indication provides a warning of the dryers need for servicing. (Audible alarm not included)
- Wall mounting kit for vertically securing the dryer to a wall or canopy.

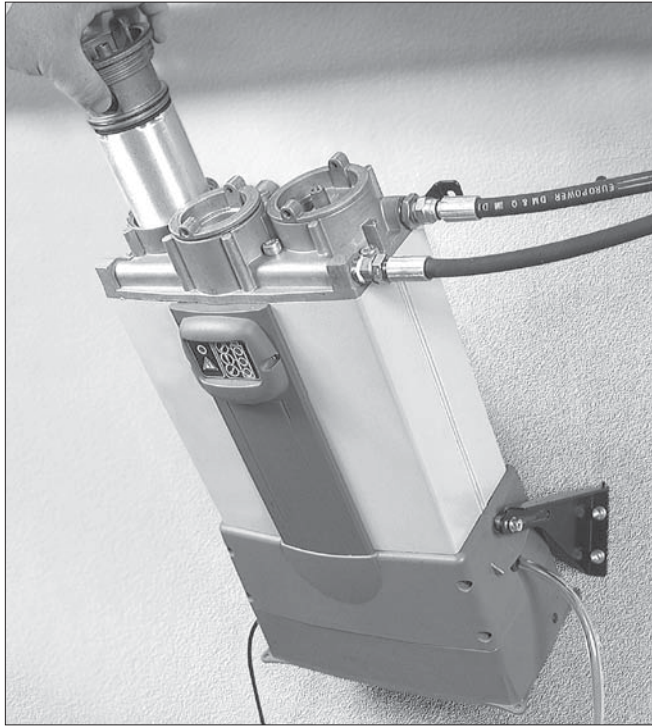

- A 45° tilt, wall mounting kit is also available for vertically securing the dryer to a wall, canopy or inside a customers product where access to the top of the dryer is restricted.
- In conditions of limited access, the electronic control box (base) can be detached and relocated remotely from the dryer.

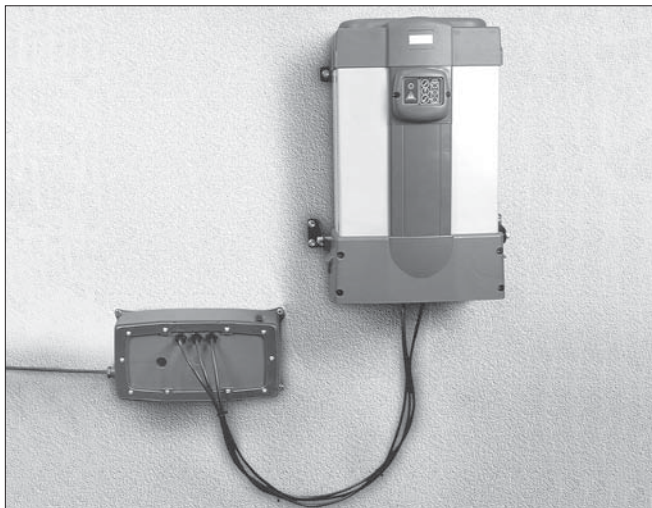

- Electronic control box can be remotely located.

Service indication sequence & alarm

During operation, The Regenerative Desiccant Dryers Power On (yellow) LED and Check (Green) LED indicators will illuminate, remaining in this configuration for 11500 hours. At this time, the Warning (Yellow) LED will illuminate and cancel the Check (Green) LED. This signals the user to order service replacement components at the optimum time.

500 hours later (a total of 12000 hours from initial start up) the Service (Red) LED will illuminate and cancel the Warning (Yellow) LED, the Audible Alarm housed inside the display will sound intermittently (every 6 seconds) drawing attention to the need for a service.

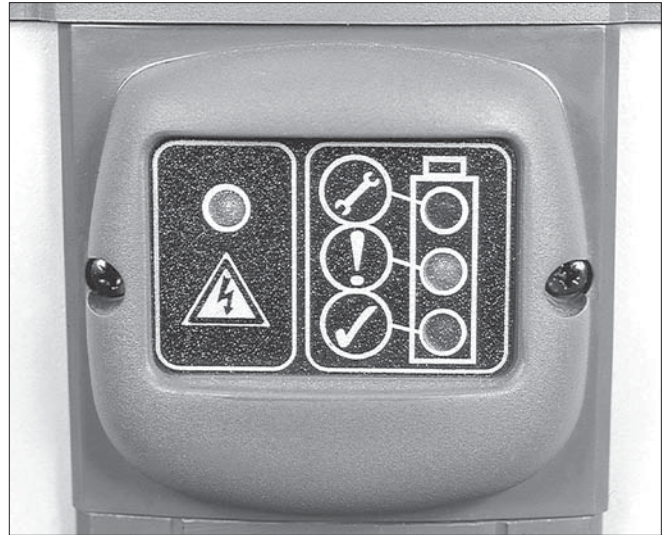

Heatless Desiccant Air Dryers

Parker PTW Series Heatless Desiccant Air Dryers remove water vapor from compressed air through a process known as pressure swing adsorption. Pressure dewpoints ranging from -40°F (-40°C) standard to -100°F (-70°C) optional are attained by directing the flow of saturated compressed air over a bed of desiccant.

Features

- Pre-filter and after filters included with dryers
- Solid state controller
- CycleLoc™ demand control
- Variable cycle control (models PTW75 - PTW800 SCFM)
- Purge Flow indicator
- Purge flow regulator (models PTW75 - PTW800 SCFM)
- Repressurization circuit (models PTW75 - PTW800 SCFM)
- Control air filter (models PTW75 - PTW800 SCFM)
- Safety valves
- Pressure equalization
- 150 PSIG design standard
- Moisture indicator (models PTW75 - PTW800 SCFM)

Options

- DDS Light / DDS (dewpoint dependent switching)

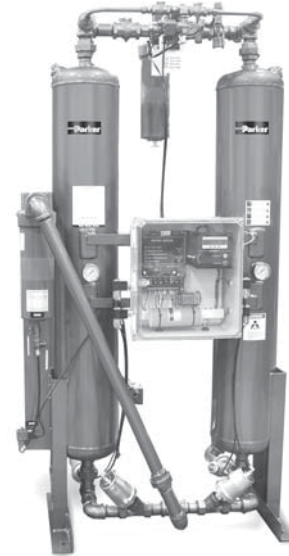

Operating information

Inlet or ambient air temperature	120°F (49°C) maximum
Operating pressure	50 PSIG (3.5 bar) minimum
Working pressure	150 PSIG (10.5 bar) maximum
Pressure drop at rated flow	less than 5 PSI (0.34 bar)

Heatless Desiccant Air Dryers

Capacity CFM @ 100 PSIG (m³/min @ 6.9 bar)	Approximate purge SCFM (Nm³/min)	Primary voltage	Part number	Port size	Filtration package included with dryer		
					Pre-filter (5µ)	Pre-filter (.01µ)	After-filter (1µ)
25 (.70)	4 (.11)	120V/1ph/60Hz	PTW25*	1/2	P32FA94FSAN	P32FA94DSAN	P32FA94QSAN
42 (1.19)	6 (.19)	120V/1ph/60Hz	PTW40*	1/2	P33FA94FSAN	P33FA94DSAN	P33FA94QSAN
60 (1.70)	9 (.25)	120V/1ph/60Hz	PTW55*	3/4	P33FA96FSAN	P33FA96DSAN	P33FA96QSAN
75 (2.13)	11 (.31)	120V/1ph/60Hz	PTW75*	3/4	P3NFA96FSA	P3NFA96DSA	P3NFA96QSA
107 (3.03)	16 (.45)	120V/1ph/60Hz	PTW100*	1	P3NFA98FSA	P3NFA98DSA	P3NFA98QSA
135 (3.82)	20 (.56)	120V/1ph/60Hz	PTW130*	1	P3NFA98FSA	P3NFA98DSA	P3NFA98QSA
200 (5.66)	30 (.84)	120V/1ph/60Hz	PTW200*	1-1/2	35F77BAP	35F77EAP	35F77HAP
250 (7.07)	38 (1.07)	120V/1ph/60Hz	PTW250*	1/1/2	35F77BAP	35F77EAP	35F77HAP
300 (8.49)	45 (1.27)	120V/1ph/60Hz	PTW300*	1-1/2	35F77BAP	35F77EAP	35F77HAP
400 (11.32)	60 (1.69)	120V/1ph/60Hz	PTW400*	2	35F87BAP	35F87EAP	35F87HAP
500 (14.44)	77 (2.18)	120V/1ph/60Hz	PTW500*	2	35F87BAP	35F87EAP	35F87HAP
600 (18.40)	98 (2.77)	120V/1ph/60Hz	PTW600*	2	35F87BAP	35F87EAP	35F87HAP
800 (22.65)	120 (3.39)	120V/1ph/60Hz	PTW800*	2	35F87BAP	35F87EAP	35F87HAP

* Options: Dewpoint dependent switching (DDS).

DDS Light includes: energy saving purge cycle control with high humidity alarm and indicator light. When ordering use -DL as suffix.

DDS includes: energy saving purge cycle control with high humidity alarm and digital dewpoint display. When ordering use -DS as suffix

 Most popular.



Heatless Desiccant Air Dryers

Parker PTW Series Heatless Desiccant Air Dryers remove water vapor from compressed air through a process known as Pressure Swing Adsorption. Pressure dewpoints ranging from -40°F (-40°C) standard to -100°F (-70°C) optional are attained by directing the flow of saturated compressed air over a bed of desiccant.

This physically tough and chemically inert material is contained in two separate but identical pressure vessels commonly referred to as “dual” or “twin” towers.

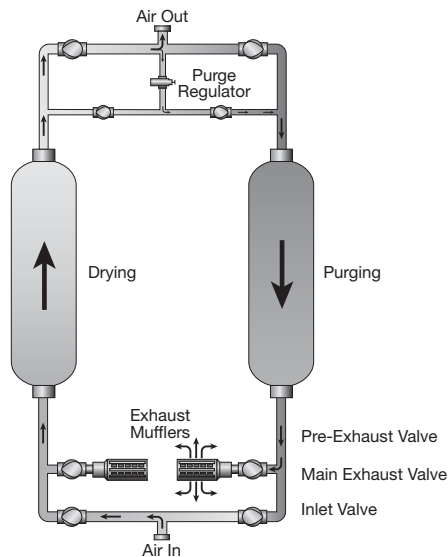

As the saturated compressed air flows up through the “on line” tower, its moisture content adheres to the surface of the desiccant. The dry compressed air is then discharged from the chamber into the distribution system.

A solid state controller automatically cycles the flow of compressed air between the towers, while the “on line” tower is drying, the “off line” tower is regenerating. Regeneration, sometimes referred to as purging, is the process by which moisture accumulated during the “on line” cycle is stripped away during the “off line” cycle. As low pressure dry purge air flows gently through the regenerating bed, it attracts the moisture that had accumulated on the surface of the desiccant during the drying cycle and exhausts it to the atmosphere.

To protect the desiccant bed from excess liquid, all Parker PTW Series Heatless Air Dryers are designed to work with the natural pull of gravity. By directing the saturated air into the bottom of the “on line” tower and flowing up through the bed, liquid condensate caused by system upset, is kept away from the desiccant and remains at the bottom of the tower where it can be easily exhausted during the regeneration cycle. Counter flow purging ensures optimum performance by keeping the driest desiccant at the discharge end of the dryer.

Moisture load, velocity, cycle time and contact time determine tower size and the amount of desiccant. To ensure design dewpoint, each tower is carefully sized to allow a minimum of 5.5 seconds of contact. To prevent desiccant dusting and bed fluidization, air flow velocities are kept below 50 feet per minute. The dryer can cycle for years without changing the desiccant.

Dryer Products PTW Series

Heatless dryers in general are the most reliable and least expensive of all desiccant type dryers. Parker PTW Series Heatless Desiccant Air Dryers are the most energy efficient thanks to standard features like, “Variable Cycle control”, “CycleLoc™” and purge flow regulator.

Standard equipment

- Electric 120V/1PH/60Hz
- Solid state controller
- Centrifugal compressor surge protection (Models PTW75 - PTW800 SCFM)
- System sequence annunciator
- CycleLoc™ demand control
- Variable cycle control (Models PTW75 - PTW800 SCFM)
- Purge flow indicator
- Purge flow regulator (Models PTW75 - PTW800 SCFM)
- Repressurization circuit (Models PTW75 - PTW800 SCFM)
- ASME coded pressure vessels (Models PTW100 - PTW800 SCFM)
- Separate tower pressure gauges
- Separate fill / drain ports
- NEMA 4 controls
- Stainless steel diffuser screen
- Pressure equalization
- 150 PSIG design standard
- Structural steel base
- Moisture indicator (PTW25 - PTW800 SCFM)
- Pre and post filtration

Optional equipment

- Dewpoint Dependent Switching (DDS)
- 4-20 mA output
- All NEMA classifications
- Pressure to 1,000 PSIG (69 bar)
- High humidity alarm
- Fail to switch alarm
- Electronic drain systems
- -80°F (-62 °C) to -100°F (-70 °C) dewpoints
- Contacts for remote alarms

Heatless Desiccant Air Dryers

Variable cycle control

Additional energy savings can be achieved by adjusting the amount of purge to the actual moisture load. When demand is expected to be less than maximum, Parker's Variable Cycle Control provides a means to adjust the purge cycle time to reduce the total amount of purge used for regeneration. As a result of less frequent cycling, the desiccant will last longer and the switching valves will require less maintenance. The Variable Cycle Control incorporates a short cycle position that can be employed to provide dewpoints as low as -80°F (-60°C).

Surge protection

To accommodate the unique requirements of centrifugal compressors, all Parker desiccant dryers are now programmed with a special anti-surge control. A sequenced timing circuit eliminates potential compressor surge by preventing momentary flow restrictions from occurring at tower switch over.

Total dryer operation is managed by a NEMA 4 automatic control center. The solid state module controls all dryer functions including the Sequence Annunciator.

Sequence annunciator

Parker's Sequence Annunciator is a solid state visual display panel that shows exactly what is happening in the dryer. The panel lights signal which tower is "on line" drying, and whether the "off line" tower is purging, repressurizing or in "CycleLoc™". It will also announce optional equipment operation and function alarms. The panel is integral with the NEMA 4 Master Control and is conveniently mounted for easy monitoring.

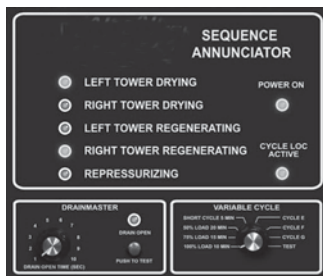

Dryer Products PTW Series

Dewpoint Dependent Switching (Optional)

Compressed air systems are rarely constant and the dryer regeneration cycle frequency is dependent upon the actual inlet flow, pressure and temperature. Operation under inlet conditions where there is lower than design flow and temperature and or higher pressure, will result in less regeneration cycles and a maximum in the cost of utilities.

Dewpoint Dependent Switching (DDS) provides a precision demand cycle control which terminates the adsorption (drying). This results in the full adsorptive capacity of the desiccant bed being utilized prior to switch over and regeneration.

DDS is built into the dryer control system, with a precision hygrometer producing a continuous display of the outlet dewpoint. The preset contacts of the instruments are utilized to initiate tower changeover.

Dewpoint Dependent Switching (DDS)

An Overview

The adsorption capacity of the desiccant within the dryer is essentially constant whereas the moisture loading and the air flow through the dryer are continuously varying as ambient and plant conditions change. In order to maintain the specified air quality downstream of the dryer, it has to be sized for the worst case conditions, namely the lowest pressure, highest flow and highest inlet temperature. These conditions may only occur for a small part of the service life of the dryer, for example, the highest inlet temperatures may only be present during the summer months. This means that the moisture loading on the desiccant beds is below the dryer's capacity for much of its service life (i.e. quiet periods in between shifts usually have lower air supply requirements). To gain access to this dynamic adsorption capacity, a moisture sensor is fitted which continually monitors the downstream dewpoint. DDS interrupts the normal sequence of the controller, which is only permitted to change over when the desiccant has adsorbed moisture to its capacity, effectively elongating the drying cycle. However, as regeneration has been optimized for a fully laden desiccant bed, this remains of constant duration resulting in a period of zero energy consumption (i.e. purging is discontinued). In this way, energy savings are obtained while maintaining a constant supply of clean dry air to your plant.



DDS



DDS Light

Flow correction factors

Capacities are based upon:

- Pressure drop at rated flow less than 5 PSI (0.34 bar)
- Maximum inlet air or ambient air temperature 120°F (49°C)
- Maximum working pressure: 150 PSIG (10.5 bar) standard units for high maximum working pressure are available
- Minimum operating pressure: 50 PSIG (3.5 bar)

Inlet air pressure correction

PSIG	50	60	70	80	90	100	110	120	130	140	150
bar	3.5	4.1	4.9	5.5	6.2	6.9	7.6	8.3	9.0	9.7	10.3
Factor	.56	.65	.74	.83	.91	1.00	1.09	1.18	1.27	1.37	1.43

Inlet air temperature correction

°F	90	95	100	105	110	115	120
°C	32	35	38	41	43	46	49
Factor	1.35	1.16	1.00	.85	.74	.64	.56

Heatless Desiccant Air Dryers

	A (length)	B (width)	C (height)	Weight lbs. (kg)	Part number
	19 (483)	16 (406)	64 (1626)	156 (71)	PTW25*
	21 (533)	17 (432)	48 (1219)	190 (86)	PTW40*
	21 (533)	20 (508)	67 (1702)	230 (104)	PTW55*
	35 (889)	27 (686)	80 (2032)	384 (174)	PTW75*
	35 (889)	27 (686)	80 (2032)	468 (212)	PTW100*
	35 (899)	21 (533)	70 (1778)	496 (225)	PTW130*
	44 (1118)	28 (711)	78 (1981)	692 (314)	PTW200*
	44 (1118)	30 (762)	78 (1981)	776 (352)	PTW250*
	44 (1118)	30 (762)	78 (1981)	796 (361)	PTW300*
	74 (1880)	41 (1041)	84 (2134)	1626 (738)	PTW400*
	74 (1880)	41 (1041)	85 (2159)	1735 (787)	PTW500*
	74 (1880)	41 (1041)	86 (2184)	1740 (789)	PTW600*
74 (1880)	41 (1041)	91 (2311)	2120 (962)	PTW800*	

Inch (mm)

* Options: Dewpoint dependent switching (DDS).

DDS Light includes: energy saving purge cycle control with high humidity alarm and indicator light. When ordering use -DL as suffix.

DDS includes: energy saving purge cycle control with high humidity alarm and digital dewpoint display. When ordering use -DS as suffix.

Service kits

Element kits

	5μ	0.01μ	1.0μ
P32	P32KA00ESE	P32KA00ESC	P32KA00ES9
P33	P33KA00ESE	P33KA00ESC	P33KA00ES9
P3NF	P3NKA00ESE	P3NKA00ESCB	P3KNA00ES9
35F	FRP-95-505	MTP-95-502	MSP-95-502

Most popular.

Drain Valve

The WDV3 Electrical Drain is designed to remove condensate from compressors, compressed air dryers and receivers up to any size, type or manufacturer.

Benefits

- Does not air-lock during operation
- Compressed air systems up to any size
- The direct acting valve is serviceable
- Suitable for all types of compressors
- Test (micro-switch) feature
- High time cycle accuracy
- Large (4.5mm) valve orifice

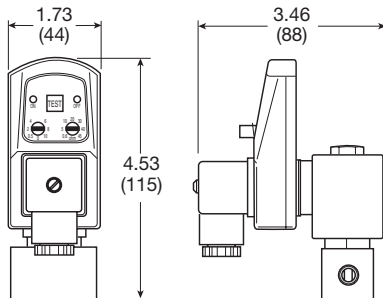

Automatic Electrical Drain Valve

Port size	Primary voltage	Weight (kg)	Model number
1/4	120VAC	1.8 (0.8 kg)	WDV3-G12BL
1/4	230VAC	1.8 (0.8 kg)	WDV3-G22BL
3/8	120VAC	1.8 (0.8 kg)	WDV3-G13BL
3/8	230VAC	1.8 (0.8 kg)	WDV3-G23BL
1/2	120VAC	1.8 (0.8 kg)	WDV3-G14BL
1/2	230VAC	1.8 (0.8 kg)	WDV3-G24BL
1/2	24VDC	1.8 (0.8 kg)	WDV3-G34BL

Air Preparation Systems Automatic Electrical Drain Valve



Operating information

Operating pressure	230 PSIG (16 bar)
Ambient operating temperature	34°F to 130°F (1.1°C to 54°C)
Voltages	115VAC, 230/50-60Hz, 24VDC
Coil Insulation	Class H, 340°F (171.1°C)
Current Rating	4mA maximum
Timer	open time .5 to 10 sec., adjustable cycle time .5 to 45 min., adjustable

Material specification

Description	
Valve Body	Brass / Stainless Steel
Enclosure (IP65 / NEMA 4)	ABS Plastic
Internal Parts	Brass / Stainless Steel
Valve Seals	FPM (Fluorocarbon)

Drain Valve

Air Preparation Systems Zero Air Loss Condensate Drains

Zero air loss condensate drains are designed for economical removal of unwanted water, oil emulsions, and other liquids. These drains will only open when liquid is present and will not allow any compressed air to escape from the system.



Operating information

Maximum pressure	232 PSIG (16 bar)
Ambient operating temperature	35°F to 140°F (1.6°C to 60°C)
Voltages	NPT 115/50-60Hz, standard
Optional:	BSPP ports 230/50-60Hz & 24VDC

Zero Air Loss Condensate Drains





Port size (NPT)	Compressor aftercooler (SCFM)*	Capacity refrigeration dryer (SCFM)**	Filter (SCFM)	Drain capacity per day (gal/liter)	Model number	Service kit
1 @ 3/8 (in), 1 @ 3/8 (out)	—	—	424	6 (22.7)	ED3002N115-K	SKED3000N115
1 @ 1/2 (in), 1 @ 3/8 (out)	141	282	1,413	13 (49.2)	ED3004N115-K	SKED3000N115
2 @ 1/2 (in), 1 @ 3/8 (out)	247	494	2,472	23 (87.1)	ED3007N115-K	SKED3000N115
2 @ 1/2 (in), 1 @ 3/8 (out)	1,059	2,119	10,594	100 (378.5)	ED3030N115-K	SKED3000N115
2 @ 1/2 (in), 1 @ 3/8 (out)	3,532	7,063	35,315	330 (1,249.2)	ED3100N115-K	SKED3000N115

* Based on 100 PSI working pressure, air compressor inlet at 77°F (25°C) at 60% RH, air discharge temperature of 95°F (35°C) following the aftercooler, pressure dewpoint of 37°F (2.8°C) after the refrigerated dryer.

** Condensate from aftercooler or refrigerated dryer to be drained upstream – only for residual oil content or small quantities of condensate.

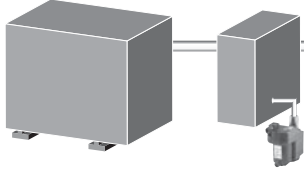
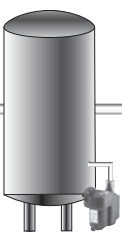
Note: A 6 ft. line cord will be included with each drain.

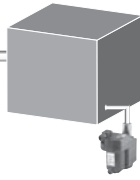
Where are condensate drains used?

				
Compressor with aftercooler	Receiver tank	Filter	Air dryer	Drip leg
Removes the condensate that is collected after the air cools in the aftercooler	Removes the condensate that is collected when the air cools inside of the receiver tank	Removes the condensate that is collected in the filter bowl	Removes the condensate that is collected in the air dryer	Point-of-use applications: removes the condensate from compressed air pipes in a plant

Dimensions

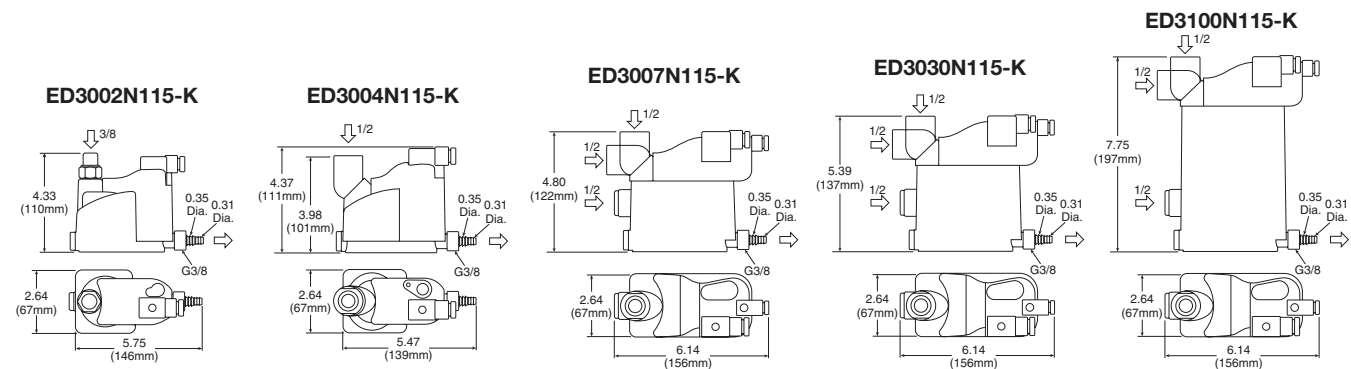

Safety Guide For Selecting And Using Pneumatic Division Products And Related Accessories

WARNING:

FAILURE OR IMPROPER SELECTION OR IMPROPER USE OF PNEUMATIC DIVISION PRODUCTS, ASSEMBLIES OR RELATED ITEMS (“PRODUCTS”) CAN CAUSE DEATH, PERSONAL INJURY, AND PROPERTY DAMAGE. POSSIBLE CONSEQUENCES OF FAILURE OR IMPROPER SELECTION OR IMPROPER USE OF THESE PRODUCTS INCLUDE BUT ARE NOT LIMITED TO:

- Unintended or mistimed cycling or motion of machine members or failure to cycle
- Work pieces or component parts being thrown off at high speeds.
- Failure of a device to function properly for example, failure to clamp or unclamp an associated item or device.
- Explosion
- Suddenly moving or falling objects.
- Release of toxic or otherwise injurious liquids or gasses.

Before selecting or using any of these Products, it is important that you read and follow the instructions below.

1. GENERAL INSTRUCTIONS

- 1.1. Scope:** This safety guide is designed to cover general guidelines on the installation, use, and maintenance of Pneumatic Division Valves, FRLs (Filters, Pressure Regulators, and Lubricators), Vacuum products and related accessory components.
- 1.2. Fail-Safe:** Valves, FRLs, Vacuum products and their related components can and do fail without warning for many reasons. Design all systems and equipment in a fail-safe mode, so that failure of associated valves, FRLs or Vacuum products will not endanger persons or property.
- 1.3 Relevant International Standards:** For a good guide to the application of a broad spectrum of pneumatic fluid power devices see: ISO 4414:1998, Pneumatic Fluid Power – General Rules Relating to Systems. See www.iso.org for ordering information.
- 1.4. Distribution:** Provide a copy of this safety guide to each person that is responsible for selection, installation, or use of Valves, FRLs or Vacuum products. Do not select, or use Parker valves, FRLs or vacuum products without thoroughly reading and understanding this safety guide as well as the specific Parker publications for the products considered or selected.
- 1.5. User Responsibility:** Due to the wide variety of operating conditions and applications for valves, FRLs, and vacuum products Parker and its distributors do not represent or warrant that any particular valve, FRL or vacuum product is suitable for any specific end use system. This safety guide does not analyze all technical parameters that must be considered in selecting a product. The user, through its own analysis and testing, is solely responsible for:
 - Making the final selection of the appropriate valve, FRL, Vacuum component, or accessory.
 - Assuring that all user’s performance, endurance, maintenance, safety, and warning requirements are met and that the application presents no health or safety hazards.
 - Complying with all existing warning labels and / or providing all appropriate health and safety warnings on the equipment on which the valves, FRLs or Vacuum products are used; and,
 - Assuring compliance with all applicable government and industry standards.
- 1.6. Safety Devices:** Safety devices should not be removed, or defeated.
- 1.7. Warning Labels:** Warning labels should not be removed, painted over or otherwise obscured.
- 1.8. Additional Questions:** Call the appropriate Parker technical service department if you have any questions or require any additional information. See the Parker publication for the product being considered or used, or call 1-800-CPARKER, or go to www.parker.com, for telephone numbers of the appropriate technical service department.

2. PRODUCT SELECTION INSTRUCTIONS

- 2.1. Flow Rate:** The flow rate requirements of a system are frequently the primary consideration when designing any pneumatic system. System components need to be able to provide adequate flow and pressure for the desired application.
- 2.2. Pressure Rating:** Never exceed the rated pressure of a product. Consult product labeling, Pneumatic Division catalogs or the instruction sheets supplied for maximum pressure ratings.
- 2.3. Temperature Rating:** Never exceed the temperature rating of a product. Excessive heat can shorten the life expectancy of a product and result in complete product failure.
- 2.4. Environment:** Many environmental conditions can affect the integrity and suitability of a product for a given application. Pneumatic Division products are designed for use in general purpose industrial applications. If these products are to be used in unusual circumstances such as direct sunlight and/or corrosive or caustic environments, such use can shorten the useful life and lead to premature failure of a product.
- 2.5. Lubrication and Compressor Carryover:** Some modern synthetic oils can and will attack nitrile seals. If there is any possibility of synthetic oils or greases migrating into the pneumatic components check for compatibility with the seal materials used. Consult the factory or product literature for materials of construction.
- 2.6. Polycarbonate Bowls and Sight Glasses:** To avoid potential polycarbonate bowl failures:
 - Do not locate polycarbonate bowls or sight glasses in areas where they could be subject to direct sunlight, impact blow, or temperatures outside of the rated range.
 - Do not expose or clean polycarbonate bowls with detergents, chlorinated hydro-carbons, keytones, esters or certain alcohols.
 - Do not use polycarbonate bowls or sight glasses in air systems where compressors are lubricated with fire resistant fluids such as phosphate ester and di-ester lubricants.

Safety Guide

2.7. Chemical Compatibility: For more information on plastic component chemical compatibility see Pneumatic Division technical bulletins Tec-3, Tec-4, and Tec-5

- 2.8. Product Rupture:** Product rupture can cause death, serious personal injury, and property damage.
- Do not connect pressure regulators or other Pneumatic Division products to bottled gas cylinders.
 - Do not exceed the maximum primary pressure rating of any pressure regulator or any system component.
 - Consult product labeling or product literature for pressure rating limitations.

3. PRODUCT ASSEMBLY AND INSTALLATION INSTRUCTIONS

- 3.1. Component Inspection:** Prior to assembly or installation a careful examination of the valves, FRLs or vacuum products must be performed. All components must be checked for correct style, size, and catalog number. DO NOT use any component that displays any signs of nonconformance.
- 3.2. Installation Instructions:** Parker published Installation Instructions must be followed for installation of Parker valves, FRLs and vacuum components. These instructions are provided with every Parker valve or FRL sold, or by calling 1-800-CPARKER, or at www.parker.com.
- 3.3. Air Supply:** The air supply or control medium supplied to Valves, FRLs and Vacuum components must be moisture-free if ambient temperature can drop below freezing

4. VALVE AND FRL MAINTENANCE AND REPLACEMENT INSTRUCTIONS

- 4.1. Maintenance:** Even with proper selection and installation, valve, FRL and vacuum products service life may be significantly reduced without a continuing maintenance program. The severity of the application, risk potential from a component failure, and experience with any known failures in the application or in similar applications should determine the frequency of inspections and the servicing or replacement of Pneumatic Division products so that products are replaced before any failure occurs. A maintenance program must be established and followed by the user and, at minimum, must include instructions 4.2 through 4.10.
- 4.2. Installation and Service Instructions:** Before attempting to service or replace any worn or damaged parts consult the appropriate Service Bulletin for the valve or FRL in question for the appropriate practices to service the unit in question. These Service and Installation Instructions are provided with every Parker valve and FRL sold, or are available by calling 1-800-CPARKER, or by accessing the Parker web site at www.parker.com.
- 4.3. Lockout / Tagout Procedures:** Be sure to follow all required lockout and tagout procedures when servicing equipment. For more information see: OSHA Standard – 29 CFR, Part 1910.147, Appendix A, The Control of Hazardous Energy – (Lockout / Tagout)
- 4.4. Visual Inspection:** Any of the following conditions requires immediate system shut down and replacement of worn or damaged components:
- Air leakage: Look and listen to see if there are any signs of visual damage to any of the components in the system. Leakage is an indication of worn or damaged components.
 - Damaged or degraded components: Look to see if there are any visible signs of wear or component degradation.
 - Kinked, crushed, or damaged hoses. Kinked hoses can result in restricted air flow and lead to unpredictable system behavior.
 - Any observed improper system or component function: Immediately shut down the system and correct malfunction.
 - Excessive dirt build-up: Dirt and clutter can mask potentially hazardous situations.

Caution: Leak detection solutions should be rinsed off after use.

4.5. Routine Maintenance Issues:

- Remove excessive dirt, grime and clutter from work areas.
- Make sure all required guards and shields are in place.

4.6. Functional Test: Before initiating automatic operation, operate the system manually to make sure all required functions operate properly and safely.

4.7. Service or Replacement Intervals: It is the user's responsibility to establish appropriate service intervals. Valves, FRLs and vacuum products contain components that age, harden, wear, and otherwise deteriorate over time. Environmental conditions can significantly accelerate this process. Valves, FRLs and vacuum components need to be serviced or replaced on routine intervals. Service intervals need to be established based on:

- Previous performance experiences.
- Government and / or industrial standards.
- When failures could result in unacceptable down time, equipment damage or personal injury risk.

4.8. Servicing or Replacing of any Worn or Damaged Parts: To avoid unpredictable system behavior that can cause death, personal injury and property damage:

- Follow all government, state and local safety and servicing practices prior to service including but not limited to all OSHA Lockout Tagout procedures (OSHA Standard – 29 CFR, Part 1910.147, Appendix A, The Control of Hazardous Energy – Lockout / Tagout).
- Disconnect electrical supply (when necessary) before installation, servicing, or conversion.
- Disconnect air supply and depressurize all air lines connected to system and Pneumatic Division products before installation, service, or conversion.
- Installation, servicing, and / or conversion of these products must be performed by knowledgeable personnel who understand how pneumatic products are to be applied.
- After installation, servicing, or conversions air and electrical supplies (when necessary) should be connected and the product tested for proper function and leakage. If audible leakage is present, or if the product does not operate properly, do not put product or system into use.
- Warnings and specifications on the product should not be covered or painted over. If masking is not possible, contact your local representative for replacement labels.

4.9. Putting Serviced System Back into Operation: Follow the guidelines above and all relevant Installation and Maintenance Instructions supplied with the valve FRL or vacuum component to insure proper function of the system.



Offer of Sale

The items described in this document and other documents and descriptions provided by Parker Hannifin Corporation, its subsidiaries and its authorized distributors ("Seller") are hereby offered for sale at prices to be established by Seller. This offer and its acceptance by any customer ("Buyer") shall be governed by all of the following Terms and Conditions. Buyer's order for any item described in its document, when communicated to Seller verbally, or in writing, shall constitute acceptance of this offer. All goods or work described will be referred to as "Products".

1. **Terms and Conditions.** Seller's willingness to offer Products, or accept an order for Products, to or from Buyer is subject to these Terms and Conditions or any newer version of the terms and conditions found on-line at www.parker.com/saleterms/. Seller objects to any contrary or additional terms or conditions of Buyer's order or any other document issued by Buyer.
2. **Price Adjustments; Payments.** Prices stated on Seller's quote or other documentation offered by Seller are valid for 30 days, and do not include any sales, use, or other taxes unless specifically stated, Unless otherwise specified by Seller, all prices are F.C.A. Seller's facility (INCOTERMS 2010). Payment is subject to credit approval and is due 30 days from the date of invoice or such other term as required by Seller's Credit Department, after which Buyer shall pay interest on any unpaid invoices at the rate of 1.5% per month or the maximum allowable rate under applicable law.
3. **Delivery Dates; Title and Risk; Shipment.** All delivery dates are approximate and Seller shall not be responsible for any damages resulting from any delay. Regardless of the manner of shipment, title to any products and risk of loss or damage shall pass to Buyer upon placement of the products with the shipment carrier at Seller's facility. Unless otherwise stated, Seller may exercise its judgment in choosing the carrier and means of delivery. No deferment of shipment at Buyers' request beyond the respective dates indicated will be made except on terms that will indemnify, defend and hold Seller harmless against all loss and additional expense. Buyer shall be responsible for any additional shipping charges incurred by Seller due to Buyer's acts or omissions.
4. **Warranty.** Seller warrants that the Products sold hereunder shall be free from defects in material or workmanship for a period of twelve months from the date of delivery to Buyer or 2,000 hours of normal use, whichever occurs first. The prices charged for Seller's products are based upon the exclusive limited warranty stated above, and upon the following disclaimer: **DISCLAIMER OF WARRANTY: THIS WARRANTY COMPRISES THE SOLE AND ENTIRE WARRANTY PERTAINING TO PRODUCTS PROVIDED HEREUNDER. SELLER DISCLAIMS ALL OTHER WARRANTIES, EXPRESS AND IMPLIED, INCLUDING DESIGN, MERCHANTABILITY AND FITNESS FOR A PARTICULAR PURPOSE.**
5. **Claims; Commencement of Actions.** Buyer shall promptly inspect all Products upon delivery. No claims for shortages will be allowed unless reported to the Seller within 10 days of delivery. No other claims against Seller will be allowed unless asserted in writing within 30 days after delivery. Buyer shall notify Seller of any alleged breach of warranty within 30 days after the date the defect is or should have been discovered by Buyer. Any action based upon breach of this agreement or upon any other claim arising out of this sale (other than an action by Seller for an amount due on any invoice) must be commenced within 12 months from the date of the breach without regard to the date breach is discovered.
6. **LIMITATION OF LIABILITY.** UPON NOTIFICATION, SELLER WILL, AT ITS OPTION, REPAIR OR REPLACE A DEFECTIVE PRODUCT, OR REFUND THE PURCHASE PRICE. IN NO EVENT SHALL SELLER BE LIABLE TO BUYER FOR ANY SPECIAL, INDIRECT, INCIDENTAL OR CONSEQUENTIAL DAMAGES ARISING OUT OF, OR AS THE RESULT OF, THE SALE, DELIVERY, NON-DELIVERY, SERVICING, USE OR LOSS OF USE OF THE PRODUCTS OR ANY PART THEREOF, OR FOR ANY CHARGES OR EXPENSES OF ANY NATURE INCURRED WITHOUT SELLER'S WRITTEN CONSENT, EVEN IF SELLER HAS BEEN NEGLIGENT, WHETHER IN CONTRACT, TORT OR OTHER LEGAL THEORY. IN NO EVENT SHALL SELLER'S LIABILITY UNDER ANY CLAIM MADE BY BUYER EXCEED THE PURCHASE PRICE OF THE PRODUCTS.
7. **User Responsibility.** The user, through its own analysis and testing, is solely responsible for making the final selection of the system and Product and assuring that all performance, endurance, maintenance, safety and warning requirements of the application are met. The user must analyze all aspects of the application and follow applicable industry standards and Product information. If Seller provides Product or system options, the user is responsible for determining that such data and specifications are suitable and sufficient for all applications and reasonably foreseeable uses of the Products or systems.
8. **Loss to Buyer's Property.** Any designs, tools, patterns, materials, drawings, confidential information or equipment furnished by Buyer or any other items which become Buyer's property, may be considered obsolete and may be destroyed by Seller after two consecutive years have elapsed without Buyer ordering the items manufactured using such property. Seller shall not be responsible for any loss or damage to such property while it is in Seller's possession or control.
9. **Special Tooling.** A tooling charge may be imposed for any special tooling, including without limitation, dies, fixtures, molds and patterns, acquired to manufacture Products. Such special tooling shall be and remain Seller's property notwithstanding payment of any charges by Buyer. In no event will Buyer acquire any interest in apparatus belonging to Seller which is utilized in the manufacture of the Products, even if such apparatus has been specially converted or adapted for such manufacture and notwithstanding any charges paid by Buyer. Unless otherwise agreed, Seller shall have the right to alter, discard or otherwise dispose of any special tooling or other property in its sole discretion at any time.
10. **Buyer's Obligation; Rights of Seller.** To secure payment of all sums due or otherwise, Seller shall retain a security interest in the goods delivered and this agreement shall be deemed a Security Agreement under the Uniform Commercial Code. Buyer authorizes Seller as its attorney to execute and file on Buyer's behalf all documents Seller deems necessary to perfect its security interest.
11. **Improper use and Indemnity.** Buyer shall indemnify, defend, and hold Seller harmless from any claim, liability, damages, lawsuits, and costs (including attorney fees), whether for personal injury, property damage, patent, trademark or copyright

infringement or any other claim, brought by or incurred by Buyer, Buyer's employees, or any other person, arising out of: (a) improper selection, improper application or other misuse of Products purchased by Buyer from Seller; (b) any act or omission, negligent or otherwise, of Buyer; (c) Seller's use of patterns, plans, drawings, or specifications furnished by Buyer to manufacture Product; or (d) Buyer's failure to comply with these terms and conditions. Seller shall not indemnify Buyer under any circumstance except as otherwise provided.

12. **Cancellations and Changes.** Orders shall not be subject to cancellation or change by Buyer for any reason, except with Seller's written consent and upon terms that will indemnify, defend and hold Seller harmless against all direct, incidental and consequential loss or damage. Seller may change product features, specifications, designs and availability with notice to Buyer.
13. **Limitation on Assignment.** Buyer may not assign its rights or obligations under this agreement without the prior written consent of Seller.
14. **Force Majeure.** Seller does not assume the risk and shall not be liable for delay or failure to perform any of Seller's obligations by reason of circumstances beyond the reasonable control of Seller (hereinafter "Events of Force Majeure") Events of Force Majeure shall include without limitation: accidents, strikes or labor disputes, acts of any government or government agency, acts of nature, delays or failures in delivery from carriers or suppliers, shortages of materials, or any other cause beyond Seller's reasonable control.
15. **Waiver and Severability.** Failure to enforce any provision of this agreement will not waive that provision nor will any such failure prejudice Seller's right to enforce that provision in the future. Invalidation of any provision of this agreement by legislation or other rule of law shall not invalidate any other provision herein. The remaining provisions of this agreement will remain in full force and effect.
16. **Termination.** Seller may terminate this agreement for any reason and at any time by giving Buyer thirty (30) days written notice of termination. Seller may immediately terminate this agreement, in writing, if Buyer: (a) commits a breach of any provision of this agreement (b) appointments a trustee, receiver or custodian for all or any part of Buyer's property (c) files a petition for relief in bankruptcy on its own behalf, or by a third party (d) makes an assignment for the benefit of creditors, or (e) the dissolves or liquidates all or a majority of its assets.
17. **Governing Law.** This agreement and the sale and delivery of all Products hereunder shall be deemed to have taken place in and shall be governed and construed in accordance with the laws of the State of Ohio, as applicable to contracts executed and wholly performed therein and without regard to conflicts of laws principles. Buyer irrevocably agrees and consents to the exclusive jurisdiction and venue of the courts of Cuyahoga County, Ohio with respect to any dispute, controversy or claim arising out of or relating to this agreement.
18. **Indemnity for Infringement of Intellectual Property Rights.** Seller shall have no liability for infringement of any patents, trademarks, copyrights, trade dress, trade secrets or similar rights except as provided in this Section. Seller will defend and indemnify Buyer against allegations of infringement of U.S. patents, U.S. trademarks, copyrights, trade dress and trade secrets ("Intellectual Property Rights"). Seller will defend at its expense and will pay the cost of any settlement or damages awarded in an action brought against Buyer based on an allegation that a Product sold pursuant to this Agreement infringes the Intellectual Property Rights of a third party. Seller's obligation to defend and indemnify Buyer is contingent on Buyer notifying Seller within ten (10) days after Buyer becomes aware of such allegations of infringement, and Seller having sole control over the defense of any allegations or actions including all negotiations for settlement or compromise. If a Product is subject to a claim that it infringes the Intellectual Property Rights of a third party, Seller may, at its sole expense and option, procure for Buyer the right to continue using the Product, replace or modify the Product so as to make it noninfringing, or offer to accept return of the Product and return the purchase price less a reasonable allowance for depreciation. Notwithstanding the foregoing, Seller shall have no liability for claims of infringement based on information provided by Buyer, or directed to Products delivered hereunder for which the designs are specified in whole or part by Buyer, or infringements resulting from the modification, combination or use in a system of any Product sold hereunder. The foregoing provisions of this Section shall constitute Seller's sole and exclusive liability and Buyer's sole and exclusive remedy for infringement of Intellectual Property Rights.
19. **Entire Agreement.** This agreement contains the entire agreement between the Buyer and Seller and constitutes the final, complete and exclusive expression of the terms of sale. All prior or contemporaneous written or oral agreements or negotiations with respect to the subject matter are herein merged.
20. **Compliance with Law, U. K. Bribery Act and U.S. Foreign Corrupt Practices Act.** Buyer agrees to comply with all applicable laws and regulations, including both those of the United Kingdom and the United States of America, and of the country or countries of the Territory in which the Buyer may operate, including without limitation the U. K. Bribery Act, the U.S. Foreign Corrupt Practices Act ("FCPA") and the U.S. Anti-Kickback Act (the "Anti-Kickback Act"), and agrees to indemnify and hold harmless Seller from the consequences of any violation of such provisions by Buyer, its employees or agents. Buyer acknowledges that they are familiar with the provisions of the U. K. Bribery Act, the FCPA and the Anti-Kickback Act, and certifies that Buyer will adhere to the requirements thereof. In particular, Buyer represents and agrees that Buyer shall not make any payment or give anything of value, directly or indirectly to any governmental official, any foreign political party or official thereof, any candidate for foreign political office, or any commercial entity or person, for the purpose of influencing such person to purchase products or otherwise benefit the business of Seller.

02/12



Parker Hannifin Corporation

Pneumatic Division

8676 E. M89

P.O. Box 901

Richland, MI 49083 USA

Tel: 269 629 5000

Fax: 269 629 5385

Applications Engineering

Phone: 877 321 4PDN Option #2

E-mail: pdnapps@parker.com

Customer Support

Phone: 877 321 4PDN Option #1

E-mail: pdncustsvc@parker.com

Web site: www.parker.com/pneumatics

